



# FIELD HANDBOOK

## **PERFORMANCE PIPE**

a division of Chevron Phillips  
Chemical Company LP

[www.driscoplex.com](http://www.driscoplex.com)

800-527-0662

## Table of Contents

NOTICE .....	8
INTRODUCTION .....	10
CAUTIONS AND NOTICES .....	11
Fusion and Joining .....	11
Leakage At Fusion Joints .....	11
Liquid Hydrocarbon Permeation .....	11
Weight, Unloading and Handling .....	12
Testing .....	12
Protection Against Shear and Bending Loads .....	12
Subfreezing Temperatures .....	13
Static Electricity .....	13
Electric Tools .....	14
Coils .....	15
Locating .....	15
Burial .....	15
Application Limitations .....	15
M & I PRODUCTS AND FEATURES .....	16
Identification Stripes and Colors .....	18
Typical Physical Properties .....	19
Pressure Rating Design .....	22
Pressure Surge .....	24
Pressure Class (PC) .....	25
Working Pressure Rating (WPR) .....	25
WPR for Typical Operating Conditions .....	26
WPR for Other Operating Conditions .....	26
Chemical Resistance .....	27
FLUID FLOW .....	28
Air Binding and Vacuum Release .....	28

Inside Diameter .....	28
Hazen-Williams .....	29
Manning .....	30
Comparative Flows for Slipliners.....	32
Compressible Gas Flow .....	36
Fitting and Valve Friction Losses .....	37
THERMAL EFFECTS .....	38
Unrestrained Thermal Effects .....	38
End Restrained Thermal Effects .....	38
Expansion Joints.....	41
Heat Transfer .....	41
ABOVE GRADE SUPPORTING.....	42
Support Spacing .....	44
BURIED PIPE DESIGN .....	47
Groundwater Flotation .....	47
WATER ENVIRONMENT DESIGN CONSIDERATIONS .....	49
External Hydraulic Pressure.....	50
Submergence Weighting.....	51
Floating Pipelines.....	55
RECEIVING AND HANDLING.....	60
Receiving Inspection .....	60
Unloading.....	61
Pre-Installation Storage .....	62
Cold Weather Handling.....	64
JOINING & CONNECTIONS .....	65
General Procedures.....	66
Heat Fusion Joining .....	67
Electrofusion .....	71
Extrusion Welding .....	71

Hot Gas Welding .....	72
Mechanical Connections .....	72
Flange Connection .....	75
Flange Assembly.....	80
Special Cases .....	82
Pipe Threads.....	83
Pullout Resistant Mechanical Joints.....	84
Partially Restrained Joints.....	85
Branch Connections.....	87
Repair Sleeves.....	89
Repair Connections.....	89
UNDERGROUND INSTALLATION.....	90
Pipe Embedment Terminology .....	91
Trenching .....	92
Placing Pipe in the Trench .....	95
Cold (Field) Bending.....	95
Installing Fabricated Fittings.....	96
Pipe Embedment Soils .....	97
Embedment Backfilling.....	97
Joint Restraining with Thrust Blocks.....	98
Controlling Shear and Bending Loads.....	98
Final Backfilling .....	101
Poisson Effects .....	101
The Poisson Effect.....	102
Connection Restraint Techniques .....	103
Pullout Prevention Techniques.....	103
Pullout Force .....	105
Special Underground Installation Techniques .....	106
Sliplining.....	111

Proprietary Trenchless Rehabilitation .....	116
SURFACE INSTALLATIONS.....	116
ABOVE GRADE INSTALLATIONS.....	119
UNDERWATER INSTALLATION .....	121
INSPECTION AND TESTING.....	122
Damage Assessment .....	122
Leak Testing .....	123
OPERATIONAL GUIDELINES .....	124
Disinfecting Water Mains .....	124
Cleaning.....	124
GENERAL INFORMATION .....	126
INDEX .....	132

## List of Tables

Table 1 DriscoPlex™ Piping Products for Municipal and Industrial Applications .....	17
Table 2 Color Stripes to Identify DR .....	19
Table 3 Typical Material Physical Properties for DriscoPlex™ PE 3408 HDPE Piping Material.....	21
Table 4 Environmental Design Factors, $f_E$ .....	23
Table 5 Service Temperature Design Factors, $f_T$ .....	23
Table 6 Surge Allowance $\diamond$ .....	27
Table 7 Hazen-Williams Friction Factor, C .....	30
Table 8 Values of n for use with Manning Equation .....	32
Table 9 Comparative Flows for Slipliners.....	34
Table 10 Fitting Equivalent Lengths, K'D .....	37
Table 11 Typical Elastic Modulus for DriscoPlex™ PE 3408 Piping.....	40
Table 12 Typical Thermal Properties for DriscoPlex™ HDPE Piping ...	42
Table 13 Support Spacing for DriscoPlex™ PE 3408 Pipes $\diamond$ .....	46
Table 14 External Pressure Resistances, psi .....	50

Table 15 Environmental Multiplier, K .....	52
Table 16 Specific Gravities Weights of Liquids at 60°F (15°C) .....	53
Table 17 Polyethylene Float Properties† .....	58
Table 18 Submergence Margin .....	59
Table 19 Submergence Factor, $f_s$ .....	59
Table 20 Suggested Jobsite Loose Storage Stacking Heights.....	64
Table 21 Approximate Butt Fusion Joining Rates .....	69
Table 22 Materials Used for Gaskets .....	76
Table 23 Flange Dimensions.....	79
Table 24 Flange Bolt Torque .....	82
Table 25 Minimum Trench Widths .....	93
Table 26 Minimum Cold (Field) Bending Radius (Long-Term) .....	96
Table 27 Approximate Poisson Effect Pullout Force .....	106
Table 28 Minimum Short-Term Bending Radius .....	107
Table 29 Recommended Design Factors for ATL .....	108
Table 30 Approximate Tensile Yield Strength Values .....	109
Table 31 Approximate ATL Values <sup>A</sup> .....	109
Table 32 Conversion Factors .....	126
Table 33 PSI Conversion Factors .....	129
Table 34 Properties of Various Liquids .....	129
Table 35 Properties of Various Gases .....	130
Table 36 Properties of Various Metals .....	131
Table 37 Formulas.....	131

## List of Figures

Figure 1 Pipeline Supporting .....	43
Figure 2 Pipeline Hanger .....	43
Figure 3 Support Spacing .....	45
Figure 4 Anti-Flotation Anchor Slab Installation .....	49
Figure 5 Concrete Ballast Weight .....	55

Figure 6 Concrete Ballast Weight ..... 55  
Figure 7 Flotation Above the Surface ..... 56  
Figure 8 Flotation On the Surface ..... 56  
Figure 9 Float Submergence..... 59  
Figure 10 Forklift Load Capacity..... 62  
Figure 11 Loose Pipe Storage..... 63  
Figure 12 Butt Fusion Bead – Visual Inspection Guidelines ..... 69  
Figure 13 DriscoPlex™ MJ Adapter with Optional Stiffener..... 73  
Figure 14 Flange Adapter and Back-Up Ring..... 75  
Figure 15 Flange Adapter and Back-Up Ring..... 76  
Figure 16 Flange Gasket Styles ..... 77  
Figure 17 Flange Bolt Length ..... 78  
Figure 18 Buried Flange-Component Connection Foundation..... 79  
Figure 19 Butterfly Valve Connections..... 83  
Figure 20 Mechanical Coupling with Insert Stiffeners ..... 84  
Figure 21 Insert Coupling ..... 85  
Figure 22 Partially Restrained Compression Coupling..... 86  
Figure 23 External Joint Restraint ..... 87  
Figure 24 Large Diameter Tee Installations ..... 88  
Figure 25 Tapping Sleeve..... 89  
Figure 26 Repair Connections..... 90  
Figure 27 Embedment Terminologies ..... 92  
Figure 28 Trench Width ..... 93  
Figure 29 Trench Box Installations ..... 94  
Figure 30 Bend Radius..... 96  
Figure 31 Haunch Tamping Tool ..... 97  
Figure 32 Controlling Shear and Bending Loads ..... 98  
Figure 33 Flange Support at Wall ..... 99  
Figure 34 Protecting Connections to Flanges and Fittings ..... 100

Figure 35 Appurtenance Support Pad .....	101
Figure 36 Pullout Prevention Technique .....	104
Figure 37 Pullout Prevention Technique .....	104
Figure 38 Sliplining Sewer Rehabilitation with DriscoPlex™ Polyethylene Pipe .....	113
Figure 39 Pulling Heads for Sliplining .....	114
Figure 40 Backhoe Slipliner Push-In Technique .....	115
Figure 41 Inserta-Tee® .....	115
Figure 42 Surface Tee Bending Protection .....	118
Figure 43 Pipe Rack, Center Anchored .....	120
Figure 44 Pipe Rack, Side Anchored .....	120
Figure 45 Deflected Pipe Installation .....	121

# ***The Performance Pipe Field Handbook***

***First Edition***

***February 2003***

## **NOTICE**

This Field Handbook contains selected information that has been excerpted and summarized from several Performance Pipe publications including the Performance Pipe Engineering Manual, technical notes, various product and application bulletins, recommended heat fusion procedures, and other publications. This handbook is intended only as a quick reference aid. The user should review the source publications for additional information. Performance Pipe literature is available on the Internet at [www.driscoplex.com](http://www.driscoplex.com) or through Performance Pipe representatives.

This Field Handbook is not a design manual and is not installation instructions, and it may not provide all necessary information, particularly with respect to special or unusual applications. It should never be substituted for the design materials, standards, and specifications available, and it should never be used in place of the advice of a qualified engineer. Performance Pipe recommends engaging the services of a qualified engineer for the evaluation of site-specific conditions, the determination of requirements and technical procedures, and to issue specific instructions for a project.

The information in this handbook is accurate to the best of Performance Pipe's knowledge, but the information in this handbook cannot be guaranteed because the conditions of use are beyond our control. This handbook may be changed from time to time without notice. Contact performance Pipe to determine if you have the most recent edition.

*All rights reserved. This publication is fully protected by copyright and nothing that appears in it may be reprinted, copied, or otherwise reproduced by any means including electronic media, either wholly or in part, without the express written permission of Performance Pipe, a division of Chevron Phillips Chemical Company LP.*

## INTRODUCTION

The Performance Pipe Field Handbook is generally directed toward municipal and industrial applications for Performance Pipe DriscoPlex™ OD controlled piping products. The Handbook includes cautions and general information, piping products and features, and general design information about fluid flows, thermal and burial effects, and general installation information about handling and storage, joining<sup>1</sup>, installation, inspection and testing, and operational guidelines. Information about DriscoPlex™ 2000 SPIROLITE® pipe, fittings, manholes, fabrications and special fabrications and Performance Pipe oilfield and gas distribution products is not included in the handbook. Please refer to specific Performance Pipe publications for information about these products.

---

<sup>1</sup> **Performance Pipe's recommended heat fusion joining procedures are published only in Bulletin PP-750, *Heat Fusion Joining Procedures and Qualification Guide* and are not reproduced in this handbook.** See also Performance Pipe Tip Cards for socket fusion (Bulletin PP-752), butt fusion (Bulletin PP-753) and saddle fusion (bulletin PP-754).

## CAUTIONS AND NOTICES

**Observe all local, state and federal codes and regulations, and general handling, installation, and construction and operating safety precautions. The following cautions should also be observed when using Performance Pipe polyethylene piping products.**

### ***Fusion and Joining***

During heat fusion, equipment and products can exceed 400°F (204°C). Take care to prevent burns. *Do not bend pipes into alignment against open butt fusion machine clamps.* The pipe may spring out and cause injury or damage.

Performance Pipe polyethylene piping products cannot be joined with adhesive or solvent cement. Pipe-thread joining and joining by hot air (gas) welding or extrusion welding techniques are not recommended for pressure service.

### ***Leakage At Fusion Joints***

***WARNING—Correctly made fusion joints do not leak. When pressurized, leakage at a faulty fusion joint may immediately precede catastrophic separation and result in violent and dangerous movement of piping or parts and the release of pipeline contents under pressure. Never approach or attempt to repair or stop leaks while the pipeline is pressurized. Always depressurize the pipeline before making corrections.***

Faulty fusion joints must be cut out and redone.

### ***Liquid Hydrocarbon Permeation***

Liquid hydrocarbon permeation may occur when liquid hydrocarbons are present in the pipe, or where soil surrounding the pipe is contaminated with liquid hydrocarbons. *Polyethylene pipe that has been permeated with liquid hydrocarbons should be joined using suitable mechanical connections* because fusion joining to liquid hydrocarbon permeated pipes may result in a low strength joint. Mechanical fittings must be installed in accordance with the fitting manufacturer's instructions.

Obtain these instructions from the fitting manufacturer. See Performance Pipe Bulletin PP 750 and the *Performance Pipe Engineering Manual*.

### ***Weight, Unloading and Handling***

Although polyethylene piping is lightweight compared to some other piping products, significant weight may be involved. Move polyethylene piping with proper handling and lifting equipment of sufficient size and capacity to handle the load. Inspect handling equipment before use. *Do not use worn or damaged equipment.*

Use fabric slings. Do not use chains or wire ropes. *Do not roll or drop pipe off the truck, or drag piping over sharp rocks or other abrasive objects.* Improper handling or abuse can damage piping and compromise system performance or cause injury or property damage.

***Obtain and observe the handling instructions provided by the delivery driver.***

Striking the pipe with an instrument such as a hammer may result in uncontrolled rebound. Store DriscoPlex™ piping products so that the potential for damage or injury is minimized. See the *Performance Pipe Engineering Manual*.

**Inclement weather can make pipe surfaces especially slippery. Do not walk on pipe, especially when footing is unsure.**

### ***Testing***

When testing is required, observe all safety measures, restrain pipe against movement in the event of catastrophic failure, and observe limitations of temperature, test pressure, test duration and making repairs. See Performance Pipe Technical Note PP-802 *Leak Testing PE Piping Systems*.

### ***Protection Against Shear and Bending Loads***

Where a polyethylene branch or service pipe is joined to a branch fitting and where pipes enter or exit casings or walls, structural support such as properly placed, compacted backfill and a protective sleeve should be used. Whether or not a protective sleeve is installed, the area surrounding the connection must be structurally supported by embedment in properly placed compacted backfill or other means to

protect the polyethylene pipe against shear and bending loads. See the Performance Pipe Engineering Manual and ASTM D 2774.

### ***Subfreezing Temperatures***

Water can be frozen solid in polyethylene pipe without damaging the pipe, but an ice plug in the pipe will stop flow. *Do not apply pressure to a frozen line that has an ice plug.* Allow ice plugging to thaw before applying pressure to the line. **Severe water hammer (such as from an ice plug stopping suddenly at an obstruction) in a frozen, surface or above grade pipeline can rupture and possibly fragment the pipeline and cause injury or property damage.**

Temperatures near or below freezing will affect polyethylene pipe by increasing stiffness and vulnerability to damage from suddenly applied stress or impact. *Significant impact or shock loads against a polyethylene pipe that is at freezing or lower temperatures can fracture the pipe.* Polyethylene pipe will be more difficult to uncoil or field bend in cold weather.

Cold temperatures will cause the pipe length and diameter to decrease.

### ***Static Electricity***

Polyethylene pipe does not readily conduct electricity. Under dry conditions such as dry gas flow inside the pipe, a static electric charge can buildup on inside and outside pipe surfaces, and stay on the surface until some grounding device such as a tool or a person comes close enough for the static electricity to discharge to the grounding device.

Discharging one part of the pipe surface will not affect other charged areas because static electricity does not flow readily from one area to another. Polyethylene pipe cannot be discharged by attaching grounding wires to the pipe.

***WARNING—Fire or Explosion—Static electric discharge can ignite a flammable gas or combustible dust atmosphere.***

A static electricity discharge to a person, a tool, or a grounded object close to the pipe surface can cause an electric shock or a spark that can ignite a flammable gas or combustible dust atmosphere causing fire or explosion.

- In gas utility applications, static electricity can be a potential safety

hazard. **Where a flammable gas- air mixture may be encountered and static charges may be present, such as when repairing a leak, squeezing off an open pipe, purging, making a connection, etc., arc preventing safety precautions are necessary. Observe all Company (pipeline operator, utility, contractor, etc.) procedures for static electricity safety and control, including procedures for discharging static electricity and requirements for personal protection.**

- Take steps to discharge static electricity from the surface of a polyethylene gas pipe. Such steps include wetting the entire exposed pipe surface with a conductive anti-static liquid or a dilute soap and water solution, then covering or wrapping the entire wetted, exposed pipe surface with grounded wet burlap, conductive poly film, or wet tape conductor. The external covering should be kept wet by occasional re-wetting with anti-static solution. The covering or tape should be suitably grounded such as to a metal pin driven into the ground.
- Procedures that discharge the outer surface do not discharge the inner surface of the pipe. Squeeze-off, purging, venting, cutting, etc., can still result in a static electricity discharge. When appropriate, ground tools and remove all potential sources of ignition.
- Appropriate personal safety equipment should be used.

**Do not use polyethylene pipe for handling dry grain or coal where a static electricity discharge may ignite a combustible dust atmosphere and cause an explosion or fire.**

Polyethylene pipe is not recommended for pneumatic slurry (pneumatic transport) applications.

### **Electric Tools**

**WARNING—Fire or Explosion—Electric tools or fusion equipment may not be explosion proof and may ignite a flammable gas or flammable dust atmosphere. DO NOT operate electrical devices that are not explosion proof in a flammable gas or flammable dust atmosphere. When a flammable gas or dust atmosphere may be present, observe all safety procedures for the use of electric tools and equipment.**

### **Coils**

Coiled HDPE pipe may contain energy as a spring. Uncontrolled release, i.e. cutting of straps, can result in dangerous uncontrolled forces. All safety precautions must be taken, and proper equipment used.

### **Locating**

Polyethylene materials are generally not detectable by standard magnetic locating equipment. There are several methods available to aid in the detection of polyethylene pipelines. These include tracer wires, identification tape, detection tape, line markers, electronic marker systems, acoustic pipe tracing and "call before you dig" line location. When installing a polyethylene pipe system, consideration should be given to a method or methods that will allow the pipeline to be located in the future. If posted signs are used to indicate the location of buried pipe, it is recommended that the signs indicate that the buried line is polyethylene. This alerts the locating personnel that the pipeline may not be identifiable by standard locating equipment. The company listed should always be contacted prior to any excavation or trenching.

### **Burial**

Consult the appropriate authority on trench construction requirements. Take all safety precautions when working in a trench.

### **Application Limitations**

Polyethylene pipes are suitable for many applications, but there are a few applications where polyethylene should not be considered or may be applicable only with appropriate precautions.

- Steam service is not recommended because steam service temperatures exceed the capabilities of PE pressure pipe.
- Dry pneumatic transport of combustible materials such as coal or food grains is not recommended, and can be extremely dangerous. Polyethylene is non-conductive. Dry, sliding friction will cause a static electric charge to build on the pipe surface. **Static electric discharge can ignite combustible dust and cause an explosion, property damage, or possible personal injury.**

- Pneumatic transport of non-combustible solids is not recommended. Particles sliding on the surface will heat and may melt the surface, and will cause static electric charges to build on the pipe surface. ***Static electric discharge can be dangerous to property or persons.***
- Above grade compressed gas (compressed air) lines are a possible safety concern. **When installed on or above grade, polyethylene may be subject to external mechanical damage. Severe damage could cause rupture and possible uncontrolled whipping. If used for compressed gas service, polyethylene pipe should be completely restrained by burial, encased in shatter-resistant materials, or otherwise protected against external mechanical damage.**

## M & I PRODUCTS AND FEATURES

Performance Pipe DriscoPlex™ OD controlled polyethylene pipe and fittings are made from high-density polyethylene materials in accordance with applicable standards, for example ASTM, AWWA or API. OD controlled DriscoPlex™ piping products are typically rated for pressure service, but may also be used for non-pressure and gravity flow applications. Product lines for particular applications are identified by a DriscoPlex™ pipe number series.

**Table 1 DriscoPlex™ Piping Products for Municipal and Industrial Applications**

<i>Typical Markets for Pipe and Fittings</i>	<i>DriscoPlex™ Series Piping Systems</i>	<i>Typical Features</i>
<i>Factory Mutual Research (FMR) Approved Underground Fire Main</i>	DriscoPlex™ 1500 pipe	2, 8, 12, 23
	DriscoPlex™ 1600 pipe	6, 12, 23, 24
<i>Mining</i>	DriscoPlex™ 1700 pipe	1, 3
<i>Perforated Pipe</i>	DriscoPlex™ 1900 pipe	1, 4
<i>Water Distribution</i>	DriscoPlex™ 4000 pipe	5, 6, 7
<i>Industrial, Water Distribution, Process</i>	DriscoPlex™ 4100 pipe	1, 8, 25, 26
<i>Water Service Tubing</i>	DriscoPlex™ 5100 pipe	9, 19
<i>Sanitary Sewer</i>	DriscoPlex™ 4200 pipe	8, 10
	DriscoPlex™ 4300 pipe	5, 6, 10
	DriscoPlex™ 2000 SPIROLITE® pipe	11
<i>Treated/Reclaimed Water</i>	DriscoPlex™ 4400 pipe	8, 13
	DriscoPlex™ 4500 pipe	5, 6, 13
<i>Sliplining</i>	DriscoPlex™ 4600 pipe	1, 14
	DriscoPlex™ 4700 pipe	5, 6, 14, 20
	DriscoPlex™ 1200 pipe	1, 15
	DriscoPlex™ 1400 pipe	5, 15
<i>Irrigation</i>	DriscoPlex™ 4800 pipe	16
<i>Dual Containment</i>	DriscoPlex™ 2400 pipe	1, 17
<i>Liner Pipe</i>	DriscoPlex™ 9200 pipe	18
<i>Manholes, Structures, Tanks</i>	DriscoPlex™ 2000 pipe	21
<i>Municipal, Industrial</i>	DriscoPlex™ 1000 pipe	1, 22
	DriscoPlex™ 8700 pipe	1, 19

**NOTICE.** Capabilities vary from manufacturing plant to manufacturing plant. Contact Performance Pipe to determine the availability of specific products and the availability of particular stripe or shell colors, striping patterns, and IPS or DIPS sizing. **All options are special order.**

**Legend for Table 1 Typical Features:**

1. IPS sizing system.
2. FMR Approved Class 150 or Class 200 in 2" – 24" IPS pipe sizes.
3. A single longitudinal color stripe is extruded into the pipe OD to identify DR.
4. Various perforation patterns are available.

5. DIPS sizing system.
6. The DIPS longitudinal color stripe pattern is three equally spaced pairs of color stripes extruded into the pipe OD.
7. Blue color stripes are standard. Optional blue color shell.
8. The IPS longitudinal color stripe pattern is four equally spaced single color stripes extruded into the pipe OD.
9. NSF Approved. CTS, IPS, and SIDR in 1/2" – 2" sizes.
10. Green color stripes are standard. Optional green color shell.
11. RSC 40-160 in 18" – 120" ID sizes in open or closed profile.
12. Red color stripes standard.
13. Purple color stripes are standard. Optional lavender color shell.
14. Solid light color.
15. Light color lining extruded into pipe ID.
16. Black PE 2406 material.
17. Factory assembled casing and carrier.
18. Custom wall thickness and diameters available on special order.
19. PE 3408/PE100 material.
20. Green color stripes are standard.
21. Manholes, tanks and special structures made from DriscoPlex™ 2000 SPIROLITE® & DriscoPlex™ PE 3408 piping products.
22. 1-1/2" IPS and smaller sizes only.
23. FMR & NSF Approved Class 150 or Class 200. Optional blue color stripes.
24. FMR Approved Class 150 or Class 200 in 4" – 24" DIPS pipe sizes.
25. Black is standard. Optional blue color stripes or blue color shell.
26. 2" IPS and 3" IPS made to ASTM D 3035, AWWA C901 and NSF 61. 4" IPS and larger made to ASTM F 714, AWWA C906 and NSF 61.

### ***Identification Stripes and Colors***

Color-coding has become the preferred way to identify differences among piping services, sizing systems, and to differentiate multiple DR's (pressure ratings) on the jobsite. For identification that is as permanent as the pipe, many DriscoPlex™ piping products have color stripes extruded into the pipe surface. Solid color pipes or a color shell extruded on the outside or inside of the pipe are also available.

#### **COLOR STRIPES (OR SHELL) TO IDENTIFY APPLICATIONS:**

- Yellow for natural gas
- Blue for potable water
- Red for underground fire main
- Green for wastewater
- Purple for treated effluent

- Other stripe colors — white, orange, gray — to meet application requirements

**COLOR STRIPE PATTERNS TO IDENTIFY SIZING SYSTEMS:**

- IPS (iron pipe) sized pipe — four color stripes equally spaced around the pipe
- DIPS (ductile iron) sized pipe — three pairs of color stripes equally spaced around the pipe

**COLOR STRIPES TO IDENTIFY DR:**

Single-striped pipe provides an easy, obvious, quick means to identify the pipe DR (dimension ratio) on a multiple DR project. Each permanent, co-extruded color designates a different DR — which determines pressure rating. Single-striped DriscoPlex™ pipe for mining, industrial and municipal applications makes installation and inspection more cost effective, and helps ensure that pipes with the correct pressure rating are installed in their proper location.

**Table 2 Color Stripes to Identify DR**

<b>Color</b>	<i>White</i>	<i>Red</i>	<i>Yellow</i>	<i>Gray</i>	<i>Orange</i>
<b>DR</b>	7.3	9	11	13.5	15.5
<b>Color</b>	<i>Blue</i>	<i>Purple</i>	<i>Green</i>	<i>Pink</i>	<i>Brown</i>
<b>DR</b>	17	21	26	32.5	41

**SOLID COLOR AND COLOR ID**

DriscoPlex™ 4600 and DriscoPlex™ 4700 solid light color pipe and DriscoPlex™ 1200 and DriscoPlex™ 1400 pipe with a light color ID lining facilitate video inspection in sewer applications.

***Typical Physical Properties***

Table 3 provides typical material physical property information for the DriscoPlex™ HDPE material used for many Performance Pipe products. Some Performance Pipe products are made from material having different typical values for one or more physical properties. Contact your Performance Pipe representative for specific product information.

### **SUNLIGHT (ULTRAVIOLET) EFFECTS**

Without chemical or physical protection, polyethylene is degraded by ultraviolet (UV) light. Because ultraviolet light is present in sunlight, protective chemical systems are compounded into polyethylene pipe to prevent or delay the onset of UV degradation and allow use or storage in direct sunlight. UV protection systems are either blocking systems that are used in black products and black products with color stripes, or sacrificial absorber systems that are used for solid color and color shell products.

Compounding 2 to 3% carbon black in the material provide long term UV protection. Very fine carbon black particles prevent UV degradation by blocking UV energy penetration. Black products and black products with color stripes are suitable for applications where there is long-term, direct exposure to ultraviolet light. This includes all surface, suspended, and above grade applications.

Sacrificial UV absorbers temporarily protect colored products by absorbing UV energy, but are used up over time. Sacrificial absorber systems provide protection for uncovered outdoor storage of several months to several years depending upon protection level and exposure level. If left exposed, material degradation will eventually occur as the absorbers in the pipe are used and the protection level drops. Covering the pipe will stop any further UV degradation effects, but will not reverse any prior exposure effects.

The sacrificial UV absorber systems in color shell and solid color products are designed only to allow a reasonable period of unprotected outdoor storage prior to installation. Color products are intended for underground service — not for surface or above grade service where there will be long-term exposure to UV light in sunlight.

Recommendations for unprotected storage outdoors of color shell and solid color products vary by product. Consult your Performance Pipe representative for information.

**Table 3 Typical Material Physical Properties for DriscoPlex™ PE 3408 HDPE Material**

<i>Property</i>	<i>Standard</i>	<i>Typical Value†</i>
Material Designation	ASTM F 412	PE 3408
Cell Classification	ASTM D 3350	345464C (black) 345464E (color)
Density [3]	ASTM D 1505	0.955 g/cc (black) 0.947 g/cc (color)
Melt Index [4]	ASTM D 1238	0.1 g/10 min
Flexural Modulus [5]	ASTM D 790	>130,000 psi
Tensile Strength [4]	ASTM D 638	3200 psi
SCG (PENT) [6]	ASTM F 1473	>100 hours
HDB at 73°F (23°C) [4]	ASTM D 2837	1600 psi
Color; UV stabilizer [C] [E]	ASTM D 3350	Black with 2-3% carbon black Color with UV stabilizer
HDB at 140°F (60°C)	ASTM D 2837	800 psi
Linear thermal expansion	ASTM D 696	$9 \times 10^{-5}$ in/in/°F
Elastic Modulus	ASTM D 638	110,000
Brittleness Temperature	ASTM D 746	< -180°F (< -118°C)
Hardness	ASTM D 2240	Shore D 65
<p>†NOTICE. This typical physical property information is for polyethylene resins used to manufacture some Performance Pipe DriscoPlex™ polyethylene piping products. It is intended for comparing polyethylene-piping resins. It is not a product specification, and it does not establish minimum or maximum values or manufacturing tolerances for resins or for piping products. These typical physical property values were determined using compression-molded plaques prepared from resin. Values obtained from tests of specimens taken from piping products can vary from these typical values. Performance Pipe has made every reasonable effort to ensure the accuracy of this information, but it may not provide all necessary information, particularly with respect to special or unusual applications. Some Performance Pipe products are made from materials having typical physical properties different from the values presented in this table. This information may be changed from time to time without notice. Contact Performance Pipe to determine if you have the most recent information.</p>		

### **Pressure Rating Design**

DriscoPlex™ PE 3408 polyethylene pipe can be applied over a wide temperature range, and perform well from -50°F (-45°C) and below, to 140°F (60°C) for pressure service, or to up to 180°F (82°C) for gravity flow (non-pressure) service. Pressurized fluids must be in a flowable liquid or gaseous state.

Gravity flow or non-pressure service above 180°F (82°C) is not recommended. Pressure service above 140°F (60°C) is not recommended. Pressure ratings are reduced at elevated temperatures (100°F (38°C) and above). See Table 5.

Black polyethylene pipe that is on the surface or above grade is usually subject to sunlight heating that will raise the pipe service temperature.

#### **Pipe Pressure Ratings**

DriscoPlex™ OD controlled pressure pipes are pressure rated using the formula below.

$$P = \frac{2HDB f_E f_T}{(DR - 1)}$$

Where:

P	=	Internal Pressure, psi
HDB	=	Hydrostatic Design Basis at 73°F, psi
f <sub>E</sub>	=	Environmental Design Factor, Table 4
f <sub>T</sub>	=	Service Temperature Design Factor, Table 5
DR	=	OD Controlled Pipe Dimension Ratio

$$DR = \frac{OD}{t}$$

OD	=	OD-Controlled Pipe Outside Diameter, in.
t	=	Pipe Minimum Wall Thickness, in.

The dimension ratio, DR, is the ratio of the wall thickness to the pipe outside diameter. As diameters change, the pressure rating is the same for the same material, dimension ratio and application.

Certain DR's that meet an ASTM-specified number series are "standard" dimension ratios, SDR's, which are: 41, 32.5, 26, 21, 17, 13.5, 11, 9, and

7.3. From one SDR to the next, there is about a 25% difference in minimum wall thickness.

Two design factors,  $f_E$  and  $f_T$ , are used to incorporate the environmental and service temperature conditions of the application into the product pressure rating. See Tables 4 and 5.

**Table 4 Environmental Design Factors,  $f_E$**

<i>Application</i>	$f_E$
Fluids such as potable and process water, benign chemicals, dry natural gas (non-federally regulated), brine, CO <sub>2</sub> , H <sub>2</sub> S, wastewater, sewage, glycol/anti-freeze solutions	0.50
Dry natural gas (Federally regulated under CFR Title 49, Part 192), Compressed air at 73°F or lower	0.32
Fluids such as solvating/permeating chemicals in pipe or soil (typically hydrocarbons) in 2% or greater concentrations, natural or other fuel-gas liquid condensates, crude oil, fuel oil, gasoline, diesel, kerosene, hydrocarbon fuels	0.25

**Table 5 Service Temperature Design Factors,  $f_T$**

<i>Service Temperature</i>	$f_T$ for PE 3408
40°F (4°C)	1.20
60°F (16°C)	1.08
73°F (23°C)	1.00
100°F (38°C)	0.78
120°F (49°C)	0.63
140°F (60°C)	0.50

Table 4 and 5 design factors are applicable to Performance Pipe polyethylene materials meeting Table 3 physical properties. They may not be applicable to other Performance Pipe materials or materials from other manufacturers.

#### FITTING PRESSURE RATINGS

Like pipe, fittings for pressure service are pressure-rated using long-term internal pressure tests. Molded fittings are pressure rated the same as

the DR of the fitting outlet. Fabricated tees and elbows made from pipe segments are pressure-rated at least one SDR higher than system pipe of the same DR. For example, a fabricated tee or elbow made from segments of DR 11 pipe is pressure rated the same as DR 13.5 pipe. Some fabricated fitting configurations such as wyes and crosses may pressure rated at lower values, or may be rated only for non-pressure service. Contact Performance Pipe for specific information. Some fabricated fittings are labeled with pressure class (PC) ratings that are for internal water pressure at 73°F (23°C). Because encasement or external reinforcement does not bond to the fitting, it cannot be used to increase fitting pressure rating.

### ***Pressure Surge***

When there is a sudden increase or decrease in water system flow velocity, a pressure surge will occur.

- Recurrent pressure surges,  $P_{RS}$ , are repetitive surge events that occur frequently such as during pump start-stop operation.
- Occasional pressure surges,  $P_{OS}$ , are irregularly occurring surges such as a sudden flow change due to firefighting or check valve operation.

Surge pressure magnitude corresponds directly to velocity change; that is, greater velocity change produces greater surge pressure.

With its unique ductile elastic properties, flexibility, resilience and superb fatigue resistance, DriscoPlex™ pipes have tremendous tolerance for surge cycles, and its low elastic modulus provides a dampening mechanism for shock loads. These short-term properties result in lower surge pressures compared to more rigid systems such as steel, ductile iron or PVC. For the same water velocity change, surge pressures in DriscoPlex™ polyethylene pipe are about 86% less than in steel pipe, about 80% less than in ductile iron pipe and about 50% less than in PVC pipe.

Unlike other plastic and metal pipes, surge pressures in DriscoPlex™ polyethylene pipe are handled above the working pressure capacity of the pipe.

### ***Pressure Class (PC)***

AWWA uses the term "Pressure Class" to define the pressure capacity under a pre-defined set of operating conditions. For polyethylene, the PC denotes the maximum allowable working pressure for water with a predefined allowance for pressure surges and a maximum pipe operating temperature of 80 °F.

Table 6 shows Working Pressure Ratings, surge allowance and corresponding allowable sudden change in flow velocity for some DR's of DriscoPlex™ polyethylene pipe. For the vast majority of municipal systems, DriscoPlex™ polyethylene water pipe has considerably more surge and velocity capabilities than necessary, even under temporary high flow conditions such as flushing or fire fighting. Surge allowance and temperature effects vary from pipe material to pipe material and erroneous conclusions may be drawn when comparing the PC of two different piping materials. For instance, the PC defined by AWWA for C900 PVC pipe includes a surge allowance for water flow at 2 ft/sec. At flow velocities above 2 ft/sec, C900 PVC pipe is de-rated. At velocities approaching 5 ft/sec, virtually the same DR is required for DriscoPlex™ polyethylene pipe and C900 PVC pipe.

### ***Working Pressure Rating (WPR)***

When water under pressure flows in a pipeline, the pipe is subjected to stress from static working pressure and transient pressure surges caused by sudden velocity changes. AWWA Standards define Working Pressure Rating (WPR) as the capacity to resist working pressure (WP) with sufficient capacity against the actual anticipated positive pressure surges above working pressure. The sustained operating pressure applied to the pipe (working pressure) must be no greater than the WPR. Pressure Class and Working Pressure Rating are closely related. Pressure Class is a rating based on operating conditions that are predefined in the AWWA Standard, where WPR is calculated based on the anticipated operating conditions of the actual application. The predetermined Pressure Class from the AWWA Standard may or may not be appropriate for the actual application.

The following relationship between WP, WPR, and PC applies:

$$WP \leq WPR \leq PC$$

**WPR for Typical Operating Conditions**

When expected flow velocities are within the limits given in Table 6, and the pipe operates at 80 °F or less, the following equation applies:

$$WPR = PC$$

**WPR for Other Operating Conditions**

WPR must be calculated for applications where the pipe operates at temperatures above 80 °F, and where exceptionally high flow demands exceed the PC surge allowance. WPR is equal to the lesser of the following three conditions:

*Condition 1* The pipe's nominal PC adjusted for temperature when above 80°F:

$$WPR = (PC)f_T$$

or

*Condition 2* One and one half times the pipe's PC adjusted for temperature less the maximum pressure resulting from recurring pressure surges ( $P_{RS}$ ):

$$WPR = 1.5(PC)f_T - P_{RS}$$

or

*Condition 3* Two times the pipe's PC adjusted for temperature less the maximum pressure resulting from occasional pressure surges ( $P_{OS}$ ):

$$WPR = 2.0(PC)f_T - P_{OS}$$

Surge allowance,  $P_{RS}$  or  $P_{OS}$ , may be approximated using the equations above. As the equations show, operating at a working pressure less than the pipe's nominal PC provides additional surge pressure capacity.

Temperature reduction factors,  $f_T$ , are presented in Table 5.

When flow velocity is at or below the value in Table 6 for the surge condition, pressure surge will not exceed the surge pressure allowance. Under these flow conditions; the working pressure rating, WPR, equals the pressure class, PC. Table 6 shows surge allowance and corresponding sudden velocity change for DR's typically used for water

distribution pipe. When flow velocity is above the values shown in table 6, WP must be reduced so that the combination of sustained and surge pressure does not exceed the WPR of the pipe. See *Condition 1*, *Condition 2* and *Condition 3* formulas above.

*Surge allowance is available only for surge events. Surge allowance is applied above the working pressure; therefore, it cannot be used to increase continuous internal pressure capacity above that permitted by the working pressure (WP).*

**Table 6 Surge Allowance**◊

DR	WPR, psi	Recurring Surge Events	
		Surge Allowance <i>P<sub>RS</sub></i> , psi	Corresponding Sudden Velocity Change, fps
21	80	40.0	4.7
17	100	50.0	5.4
13.5	130	64.0	6.3
11	160	80.0	7.0
DR	WPR, psi	Occasional Surge Events	
		Surge allowance <i>P<sub>OS</sub></i> , psi	Corresponding Sudden Velocity Change, fps
21	80	80	9.3
17	100	100	10.8
13.5	130	130	12.4
11	160	160	14.0

◊ Pressure and velocity ratings are for water at 80°F (27°C) or less, and can vary for other fluids and temperatures.

### Chemical Resistance

Information about short-term chemical immersion tests of unstressed specimens is published in the *Performance Pipe Engineering Manual*, PP-900. Additional information on chemical compatibility may be found in *PPI TR-19, Thermoplastic Piping for the Transport of Chemicals*. Because the particular conditions of an application may vary, short-term, unstressed chemical immersion test information should be used only as a preliminary guide.

***The apparent absence of effect in a short-term immersion test does not imply that there will be no effect where there is long-term exposure or applied stress or combinations chemicals or elevated temperature either individually or in any combination.***

Where information about the suitability of polyethylene piping for use with chemicals or chemical combinations for a particular application or environment is not available, tests should be conducted to determine suitability. *Performance Pipe cannot provide chemical testing services.*

## **FLUID FLOW**

DriscoPlex™ polyethylene pipe is used to transport fluids that may be liquid or slurry, where solid particles are entrained in a liquid, or gas. This section provides general information for Hazen-Williams and Manning water flow and for Mueller high-pressure and low-pressure gas flow<sup>2</sup>. The flow information in this section may apply to certain conditions and applications, but it is not suitable for all applications. The user should determine applicability before use.

### ***Air Binding and Vacuum Release***

In rolling or mountainous country, additional drag due to air binding must be avoided. Air binding occurs when air in the system accumulates at local high spots. This reduces the effective pipe bore, and restricts flow. Vents such as standpipes or air release valves may be installed at high points to avoid air binding. If the pipeline has a high point above that of either end, vacuum venting may be required to prevent vacuum collapse, siphoning, or to allow drainage.

### ***Inside Diameter***

OD controlled DriscoPlex™ polyethylene pipe is made using an extrusion process that controls the outside diameter and wall thickness. As a result, the inside diameter will vary according to the combined OD and wall thickness tolerances and other variables including toe-in, out of roundness, ovality, installation quality, temperature and the like. An inside diameter for flow calculations is typically determined by deducting

---

<sup>2</sup> For flow formulas that require a surface roughness value,  $\epsilon = 7 \times 10^{-5}$  ft. is typically used for HDPE pipe.

two times the average wall thickness from the average OD. Average wall thickness is minimum wall thickness plus 6%.

When an actual ID is required for devices such as inserts or stiffeners that must fit precisely in the pipe ID, please refer to the manufacturing standard (ASTM, AWWA, etc.) or take actual measurements from the pipe.

### **Hazen-Williams**

For some applications, empirical formulas are available, and when used within their limitations, reliable results can be obtained with greater convenience. Hazen and Williams developed an empirical formula for water at 60° F. Water's viscosity varies with temperature, so some error can occur at other temperatures.

Hazen-Williams formula for friction (head) loss in feet:

$$h_f = \frac{0.002083 L}{d^{4.8655}} \left( \frac{100 Q}{C} \right)^{1.85}$$

Hazen-Williams formula for friction (head) loss in psi:

$$p_f = \frac{0.0009015 L}{d^{4.8655}} \left( \frac{100 Q}{C} \right)^{1.85}$$

Where

- $h_f$  = friction (head) loss, feet of water
- $L$  = pipe length, ft
- $d$  = pipe inside diameter, in.
- $Q$  = flow, gal./min.
- $C$  = Hazen-Williams Friction Factor, dimensionless
- $p_f$  = friction (head) loss for water, psi

**Table 7 Hazen-Williams Friction Factor, C**

Pipe Material	Values for C		
	Range High / Low	Average Value	Typical Design Value
Polyethylene pipe or tubing	160 / 150	150-155 <sup>A</sup>	150
Cement or mastic lined iron or steel pipe	160 / 130	148	140
Copper, brass, lead, tin or glass pipe or tubing	150 / 120	140	130
Wood stave	145 / 110	120	110
Welded and seamless steel	150 / 80	130	100
Cast and ductile iron	150 / 80	130	100
Concrete	152 / 85	120	100
Corrugated steel	–	60	60

<sup>A</sup> Determined on butt fused pipe with internal beads in place.

Water flows through pipes of different materials and diameters may be compared using the following formula. The subscripts 1 and 2 refer to the known pipe and the unknown pipe.

$$\% \text{ flow} = 100 \frac{d_2}{d_1} \left( \frac{C_2}{C_1} \right)^{0.3806}$$

### **Manning**

For open channel water flow under conditions of constant grade, and uniform channel cross section, the Manning equation may be used. Open channel flow exists in a pipe when it runs partially full. Like the Hazen-Williams formula, the Manning equation is limited to water or liquids with a kinematic viscosity equal to water.

Manning Equation

$$V = \frac{1.486}{n} r^{2/3} S^{1/2}$$

where

- V = flow velocity, ft/sec  
 n = roughness coefficient, dimensionless (Table 8)  
 r = hydraulic radius, ft

$$r = \frac{A}{P}$$

- A = channel cross section area, ft<sup>2</sup>  
 P = perimeter wetted by flow, ft  
 S = hydraulic slope, ft/ft

$$S = \frac{h_1 - h_2}{L} = \frac{h_f}{L}$$

- h<sub>1</sub> = upstream pipe elevation, ft  
 h<sub>2</sub> = downstream pipe elevation, ft  
 h<sub>f</sub> = friction (head) loss, ft of liquid

It is convenient to combine the Manning equation with

$$Q = AV$$

To obtain

$$Q = \frac{1.486 A}{n} r^{2/3} S^{1/2}$$

Where terms are as defined above, and

- Q = flow, cu-ft/sec

When a circular pipe is running full or half-full,

$$r = \frac{D}{4} = \frac{d}{48}$$

Where

- D = pipe bore, ft  
 d = pipe bore, in

Full pipe flow in cu-ft per second may be estimated using:

$$Q = \left( 6.136 \times 10^{-4} \right) \frac{d^{8/3} S^{1/2}}{n}$$

Full pipe flow in gallons per minute may be estimated using:

$$Q' = 0.275 \frac{d^{8/3} S^{1/2}}{n}$$

Nearly full circular pipes will carry more liquid than a completely full pipe. When slightly less than full, the hydraulic radius is significantly reduced, but the actual flow area is only slightly lessened. Maximum flow is achieved at about 93% of full pipe flow, and maximum velocity at about 78% of full pipe flow.

**Table 8 Values of n for use with Manning Equation**

<i>Surface</i>	<i>n, range</i>	<i>n, typical design</i>
Polyethylene pipe	0.008 – 0.011	0.009
Uncoated cast or ductile iron pipe	0.012 – 0.015	0.013
Corrugated steel pipe	0.021 – 0.030	0.024
Concrete pipe	0.012 – 0.016	0.015
Vitrified clay pipe	0.011 – 0.017	0.013
Brick and cement mortar sewers	0.012 – 0.017	0.015
Wood stave	0.010 – 0.013	0.011
Rubble masonry	0.017 – 0.030	0.021

### ***Comparative Flows for Slipliners***

Sliplining rehabilitation of deteriorated gravity flow sewers involves installing a polyethylene liner inside of the original pipe. For conventional sliplining, clearance between the liner outside diameter, and the existing pipe bore is required to install the liner. So after rehabilitation, the flow channel is smaller than the original pipe. However, DriscoPlex™ polyethylene pipe has a smooth surface that resists aging and deposition. It may be possible to slipline, and maintain all or most of the original flow capacity. See Table 9

Comparative flow capacities of circular pipes may be determined by the following:

$$\% \text{ flow} = 100 \frac{Q_1}{Q_2} = 100 \frac{\left( \frac{d_1^{8/3}}{n_1} \right)}{\left( \frac{d_2^{8/3}}{n_2} \right)}$$

Table 9 was developed using the above formula where  $d_1$  = the liner ID, and  $d_2$  = the existing sewer ID.

**Table 9 Comparative Flows for Slipliners**

Existing Sewer ID, in	Liner OD, in.	Liner DR 32.5			Liner DR 26			Liner DR 21			Liner DR 17		
		Liner ID, in.	% flow vs. concrete	% flow vs. clay	Liner ID, in.	% flow vs. concrete	% flow vs. clay	Liner ID, in.	% flow vs. concrete	% flow vs. clay	Liner ID, in.	% flow vs. concrete	% flow vs. clay
4	3.500	3.272	97.5%	84.5%	3.215	93.0%	80.6%	3.147	87.9%	76.2%	3.064	81.8%	70.9%
6	4.500	4.206	64.6%	56.0%	4.133	61.7%	53.5%	4.046	58.3%	50.5%	3.939	54.3%	47.0%
6	5.375	5.024	103.8%	90.0%	4.937	99.1%	85.9%	4.832	93.6%	81.1%	4.705	87.1%	75.5%
8	6.625	6.193	84.2%	73.0%	6.085	80.3%	69.6%	5.956	75.9%	65.8%	5.799	70.7%	61.2%
8	7.125	6.660	102.2%	88.6%	6.544	97.5%	84.5%	6.406	92.1%	79.9%	6.236	85.8%	74.4%
10	8.625	8.062	93.8%	81.3%	7.922	89.5%	77.6%	7.754	84.6%	73.3%	7.549	78.8%	68.3%
12	10.750	10.049	103.8%	90.0%	9.873	99.1%	85.9%	9.665	93.6%	81.1%	9.409	87.1%	75.5%
15	12.750	11.918	90.3%	78.2%	11.710	86.1%	74.6%	11.463	81.4%	70.5%	11.160	75.7%	65.6%
15	13.375	12.503	102.5%	88.9%	12.284	97.8%	84.8%	12.025	92.4%	80.1%	11.707	86.1%	74.6%
16	14.000	13.087	97.5%	84.5%	12.858	93.0%	80.6%	12.587	87.9%	76.2%	12.254	81.8%	70.9%
18	16.000	14.956	101.7%	88.1%	14.695	97.0%	84.1%	14.385	91.7%	79.4%	14.005	85.3%	74.0%
21	18.000	16.826	92.3%	80.0%	16.532	88.1%	76.3%	16.183	83.2%	72.1%	15.755	77.5%	67.1%
24	20.000	18.695	85.6%	74.2%	18.369	81.7%	70.8%	17.981	77.2%	66.9%	17.506	71.9%	62.3%

Performance Pipe Field Handbook

Existing Sewer ID, in	Liner OD, in.	Liner DR 32.5			Liner DR 26			Liner DR 21			Liner DR 17		
		Liner ID, in.	% flow vs. concrete	% flow vs. clay	Liner ID, in.	% flow vs. concrete	% flow vs. clay	Liner ID, in.	% flow vs. concrete	% flow vs. clay	Liner ID, in.	% flow vs. concrete	% flow vs. clay
24	22.000	20.565	110.4%	95.7%	20.206	105.3%	91.3%	19.779	99.5%	86.2%	19.256	92.6%	80.3%
27	24.000	22.434	101.7%	88.1%	22.043	97.0%	84.1%	21.577	91.7%	79.4%	21.007	85.3%	74.0%
30	28.000	26.174	115.8%	100.4%	25.717	110.5%	95.8%	25.173	104.4%	90.5%	24.508	97.2%	84.2%
33	30.000	28.043	108.0%	93.6%	27.554	103.0%	89.3%	26.971	97.3%	84.3%	26.259	90.6%	78.5%
36	32.000	29.913	101.7%	88.1%	29.391	97.0%	84.1%	28.770	91.7%	79.4%	28.009	85.3%	74.0%
36	34.000	31.782	119.5%	103.6%	31.228	114.1%	98.9%	30.568	107.7%	93.4%	29.760	100.3%	86.9%
42	36.000	33.652	92.3%	80.0%	33.065	88.1%	76.3%	32.366	83.2%	72.1%	31.511	77.5%	67.1%
48	42.000	39.260	97.5%	84.5%	38.575	93.0%	80.6%	37.760	87.9%	76.2%	36.762	81.8%	70.9%
54	48.000	44.869	101.7%	88.1%	44.086	97.0%	84.1%	43.154	91.7%	79.4%	42.014	85.3%	74.0%
60	54.000	50.478	105.1%	91.1%	49.597	100.3%	86.9%	48.549	94.8%	82.1%	47.266	88.2%	76.5%

### Compressible Gas Flow

Flow formulas for smooth pipe may be used to estimate gas flow rates through DriscoPlex™ polyethylene pipe.

#### HIGH PRESSURE GAS FLOW

For pressures greater than 1 psig, the high-pressure Mueller equation may be used. Due to assumptions made in the equation, actual flow may differ from the calculated result.

High-Pressure Mueller Equation

$$Q_h = \frac{2826 d^{2.725}}{S_g^{0.425}} \left( \frac{p_1^2 - p_2^2}{L} \right)^{0.575}$$

Where

- Q<sub>h</sub> = flow, standard ft<sup>3</sup>/hour
- S<sub>g</sub> = gas specific gravity (Table 35)
- p<sub>1</sub> = inlet pressure, lb/in<sup>2</sup> absolute
- p<sub>2</sub> = outlet pressure, lb/in<sup>2</sup> absolute
- L = length, ft
- d = pipe bore, in

#### LOW PRESSURE GAS FLOW

For applications where less than 1 psig is encountered, such as landfill gas gathering or wastewater odor control, the low-pressure Mueller equation may be used.

Low-Pressure Mueller Equation

$$Q_h = \frac{2971 d^{2.725}}{S_g^{0.425}} \left( \frac{h_1 - h_2}{L} \right)^{0.575}$$

Where terms are as defined previously, and

- h<sub>1</sub> = inlet pressure, in H<sub>2</sub>O
- h<sub>2</sub> = outlet pressure, in H<sub>2</sub>O

**Fitting and Valve Friction Losses**

Fluids flowing through a fitting or valve will experience a friction loss, which is frequently expressed as an equivalent length of pipe.

Equivalent length is found by multiplying the applicable resistance coefficient,  $K'$ , for the fitting by the pipe diameter,  $D$ , in feet.

$$L = K'D$$

**Table 10 Fitting Equivalent Lengths,  $K'D$** 

<i>Fitting</i>	<i>K'D</i>
90° molded elbow	30 D
45° molded elbow	16 D
15° fabricated elbow	4 D
22.5° fabricated elbow	6 D
30° fabricated elbow	8 D
45° fabricated elbow	12 D
60° fabricated elbow	16 D
67.5° fabricated elbow	18 D
75° fabricated elbow	20 D
90° fabricated elbow	24 D
Equal outlet tee, run/branch	60 D
Equal outlet tee, run/run	20 D
Conventional globe valve, full open	350 D
Conventional angle valve, full open	180 D
Conventional Wedge Gate Valve, full open	15 D
Butterfly valve, full open	40 D
Conventional swing check valve	100 D

## THERMAL EFFECTS

In response to changing temperature, unrestrained polyethylene pipe will undergo a length change. Anchored or end restrained pipe will develop longitudinal stresses instead of undergoing a change in length. This stress will be tensile during temperature decrease, or compressive during temperature increase. If the compressive stress level exceeds the column buckling resistance of the restrained length, then lateral buckling (or snaking) will occur. While thermal effect stresses are well tolerated by polyethylene pipe, anchored or restrained pipe may apply stress to restraining structures. Restraining structures must be designed to resist thermal effect loads that can be significant, particularly during thermal contraction.

### *Unrestrained Thermal Effects*

The theoretical length change for an unrestrained pipe on a frictionless surface is:

$$\Delta L = L \alpha \Delta T$$

Where:

$\Delta L$	=	length change, in
$L$	=	pipe length, in
$\alpha$	=	thermal expansion coefficient, in/in/°F
	=	about $9.0 \times 10^{-5}$ in/in/°F for DriscoPlex™ PE 3408
$\Delta T$	=	temperature change, °F

An approximate “rule of thumb” is 1/10/100, that is, 1 in for each 10° F change for each 100 ft of pipe. This is a significant length change compared to other piping materials and should be taken into account when designing unrestrained piping such as surface and above grade piping. A temperature rise results in a length increase while a temperature drop results in a length decrease.

### *End Restrained Thermal Effects*

A length of pipe that is restrained or anchored on both ends and subjected to a temperature decrease will apply significant tensile loads on the end restraints. Thermal contraction tensile stress can be

determined using:

$$\sigma = E \alpha \Delta T$$

Where terms are as defined above, and

- $\sigma$  = longitudinal stress in pipe, psi
- $E$  = elastic modulus, psi (Table 11)

**The selection of the modulus can have a large impact on the calculated stress.** When determining the appropriate time interval, consider that heat transfer occurs at relatively slow rates through the wall of polyethylene pipe, so temperature changes do not occur rapidly. Therefore, the average temperature is often chosen when selecting an elastic modulus.

As longitudinal tensile stress builds in the pipe wall, a thrust load is created on the end structures. This load can be significant and may be determined using:

$$F = \sigma A$$

Where terms are as defined above, and

- $F$  = end thrust, lb
- $A$  = cross section area of pipe, in<sup>2</sup>

**Table 11 Typical Elastic Modulus for DriscoPlex™ PE 3408 Pipe Resin**

Load Duration	Elastic Modulus†, 1000 psi (MPa), at Temperature, °F (°C)							
	-20 (-29)	0 (-18)	40 (4)	60 (16)	73 (23)	100 (38)	120 (49)	140 (60)
Short-Term	300.0 (2069)	260.0 (1793)	170.0 (1172)	130.0 (896)	110.0 (758)	100.0 (690)	65.0 (448)	50.0 (345)
10 h	140.8 (971)	122.0 (841)	79.8 (550)	61.0 (421)	57.5 (396)	46.9 (323)	30.5 (210)	23.5 (162)
100 h	125.4 (865)	108.7 (749)	71.0 (490)	54.3 (374)	51.2 (353)	41.8 (288)	27.2 (188)	20.9 (144)
1000 h	107.0 (738)	92.8 (640)	60.7 (419)	46.4 (320)	43.7 (301)	35.7 (246)	23.2 (160)	17.8 (123)
1 y	93.0 (641)	80.6 (556)	52.7 (363)	40.3 (278)	38.0 (262)	31.0 (214)	20.2 (139)	15.5 (107)
10 y	77.4 (534)	67.1 (463)	43.9 (303)	33.5 (231)	31.6 (218)	25.8 (178)	16.8 (116)	12.9 (89)
50 y	69.1 (476)	59.9 (413)	39.1 (270)	29.9 (206)	28.2 (194)	23.0 (159)	15.0 (103)	11.5 (79)

† Typical values based on ASTM D 638 testing of molded plaque material specimens.

Flexible polyethylene pipe does not transmit compressive force very well. During temperature increase, the pipe usually will deflect laterally (snake sideways) before developing significant compressive force on structural restraints. Lateral deflection may be approximated by

$$y = L \sqrt{\frac{\alpha \Delta T}{2}}$$

Where

- y = lateral deflection, in
- L = distance between endpoints, in
- α = thermal expansion coefficient, in/in/°F
- ΔT = temperature change, °F

A long, semi-restrained pipe run can snake to either side of the run centerline. Total deflection is

$$Y_T = 2(\Delta y) + D$$

Where terms are as defined above and

$Y_T$  = total deflection, in  
D = pipe diameter, in

To minimize thrust loads on restraints or to control which side of the centerline the pipe snakes, an initial deflection can be provided so the pipe does not contract to a straight line at minimum expected temperature. Likewise, during thermal expansion, pipe that is pre-snaked requires less force than predicted to continue snaking. At the time of installation, the anticipated temperature change from installation temperature to minimum temperature should be determined. Using this temperature change and the distance between points, determine lateral deflection, and install the pipe with this lateral deflection plus the minimum lateral deflection specified by the designer.

Care should be taken to ensure that thermal expansion deflection does not result in kinking. Thermal expansion deflection bending should not result in a bend that is tighter than the minimum long-term cold field-bending radius in Table 26.

### ***Expansion Joints***

In general, expansion joints are not recommended for use with HDPE pipe, especially in pressure service. If used, expansion joints must be specifically intended for use with HDPE pipe to activate at very low longitudinal forces and permit large movements. Expansion joints intended for use with other piping materials are not recommended for several reasons. (1) Expansion allowance is frequently insufficient for polyethylene. (2) The force required to activate the joint may exceed the column buckling strength of the polyethylene pipe. (3) Expansion joints for pressure service may include internal components that when pressurized, will place an end load on the pipe. HDPE pipe has low resistance to end loads, and likely will deflect sideways rather than compress the expansion joint. Contact the expansion joint manufacturer prior to use.

### ***Heat Transfer***

Polyethylene pipe may be heat traced, insulated, or both. Temperature limited (120°F maximum) heat tracing tape should be used, and the tape

should be installed over a pressure-sensitive metallic tape installed on the pipe. The metallic tape helps distribute heat over the pipe surface.

Thermal conductivity terms:

$C$  = thermal conductance, BTU/(hr-ft<sup>2</sup>-°F)

$$C = \frac{k}{t} = \frac{1}{R}$$

$t$  = thickness, in

**Table 12 Typical Thermal Properties for DriscoPlex™ HDPE**

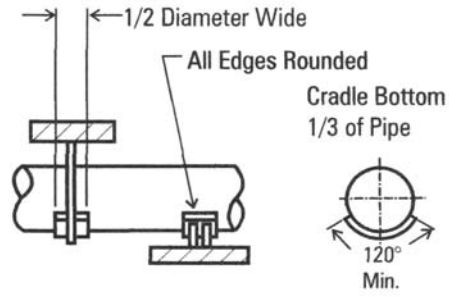
<i>Property</i>	<i>ASTM Reference</i>	<i>Nominal Value</i>
Thermal Conductivity, $k$	C 177	3.5 Btu/(h-ft <sup>2</sup> -°F-in)
Thermal Resistance, $R$ (1" thickness)	–	0.3 (hr-ft <sup>2</sup> -°F)/Btu

## ABOVE GRADE SUPPORTING

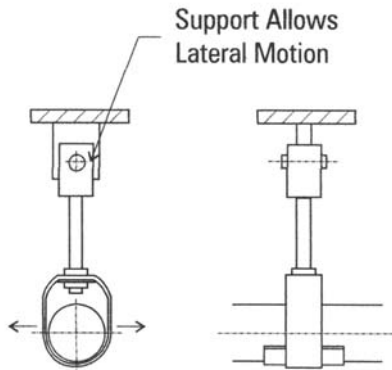
Above grade applications frequently require non-continuous support for DriscoPlex™ OD controlled polyethylene pipe. Such applications usually involve piping in a rack or trestle, on sleepers, or suspended from an overhead structure. In such cases, the pipeline must be properly supported, thermal expansion and contraction movement must be accommodated, and supports must be spaced to limit vertical deflection between supports.

Supports for DriscoPlex™ OD controlled pipe must cradle at least the bottom 120° of the pipe, and be at least 1/2 pipe diameter wide. Edges should be rounded or rolled to prevent cutting into the pipe. Commercial pipe supports such as u-bolts, narrow strap-type hangers, and roller type supports are unsuitable unless modified for width and cradling. The weight of the pipe and its contents must be distributed over a broad surface. Narrow support surfaces can produce high concentrated stress, and possibly lead to pipeline failure. Figures 1 and 2 illustrate supports and hangers.

**Figure 1 Pipeline Supporting**



**Figure 2 Pipeline Hanger**



### Support Spacing

Support spacing depends upon the allowable deflection between supports, which in turn depends upon the pipeline, the fluid within it, and the service temperature. Performance Pipe recommends that the allowable long-term deflection between supports should not exceed 1". Recommended support spacing may be determined from the following:

$$L_S = \sqrt[4]{\frac{384 E I y_S}{5 (W_P + W_F)}}$$

where:

- $L_S$  = distance between supports, in
- $E$  = long-term modulus for the service temperature, lb/in<sup>2</sup>  
(See Table 11)
- $I$  = moment of inertia, in<sup>4</sup>
- $y_S$  = deflection between supports, in
- $W_P$  = weight of pipe, lb/in
- $W_F$  = weight of fluid in pipe, lb/in

Each support along a piping run is loaded from both sides. When run supports are equally spaced, the load on supports along the run is:

$$W_{RUN} = L (W_P + W_F)$$

where:

- $W_{RUN}$  = load on supports along the run, lb

When supports are at the beginning or end of the run, the supports are loaded from only one side, thus the load on end supports is:

$$W_{END} = \frac{L (W_P + W_F)}{2}$$

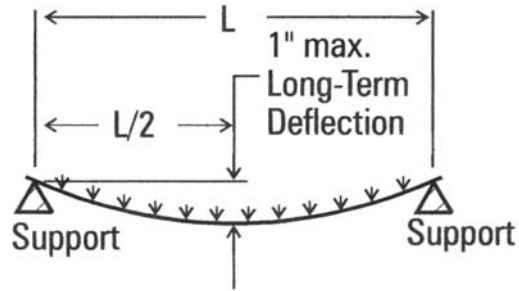
Where:

- $W_{END}$  = load on end supports, lb

The support spacing values in Table 13 were determined using a 1 in. deflection for DriscoPlex™ PE 3408 pipes filled with water at 73°F

(23°C). Support spacing will be greater at lower temperatures and when the pipe is not completely filled or fluid in the pipe is lighter than water (gases, etc.). Support spacing will be reduced for higher temperatures and for fluids in the pipe that are heavier than water (brine, slurries, etc.). The support spacing formulas in this section or in the *Performance Pipe Engineering Manual* (PP-900) should be used to determine support spacing when conditions vary from those in Table 13.

**Figure 3 Support Spacing**



**Table 13 Support Spacing for DriscoPlex™ PE 3408 Pipes**◇

IPS size	OD, IN	Support Spacing, ft								
		DR 7.3	DR 9	DR 11	DR 13.5	DR 17	DR 21	DR 26	DR 32.5	DR 41
2	2.375	5.3	5.1	4.9						
3	3.500	6.4	6.2	6.0	5.8	5.5	5.3			
4	4.500	7.3	7.0	6.8	6.5	6.3	6.0	5.7	5.4	
5	5.563	8.1	7.8	7.6	7.3	7.0	6.7	6.4	6.0	
6	6.625	8.8	8.5	8.3	7.9	7.6	7.3	6.9	6.6	
8	8.625	10.1	9.7	9.4	9.1	8.7	8.3	7.9	7.5	
10	10.750	11.2	10.9	10.5	10.1	9.7	9.2	8.8	8.4	
12	12.750	12.2	11.9	11.5	11.0	10.5	10.1	9.6	9.1	
14	14.000	12.8	12.4	12.0	11.5	11.0	10.6	10.1	9.6	
16	16.000	13.7	13.3	12.8	12.3	11.8	11.3	10.8	10.2	
18	18.000	14.5	14.1	13.6	13.1	12.5	12.0	11.4	10.9	
20	20.000	15.3	14.8	14.3	13.8	13.2	12.6	12.0	11.5	
22	22.000	16.1	15.6	15.0	14.5	13.8	13.2	12.8	12.0	
24	24.000	16.8	16.3	15.7	15.1	14.4	13.8	13.2	12.5	
26	26.000	17.5	16.9	16.3	15.7	15.0	14.4	13.7	13.1	
28	28.000		17.6	17.0	16.3	15.6	14.9	14.2	13.5	
30	30.000		18.2	17.6	16.9	16.1	15.4	14.7	14.0	13.3
32	32.000		18.8	18.1	17.5	16.7	15.9	15.2	14.5	13.7
34	34.000			18.7	18.0	17.2	16.4	15.7	14.9	14.2
36	36.000			19.2	18.5	17.7	16.9	16.2	15.4	14.6
42	42.000				20.0	19.1	18.3	17.4	16.6	15.7
48	48.000				21.4	20.4	19.5	18.6	17.7	16.8
54	54.000					21.7	20.7	19.8	18.8	17.8

◇ Support spacing is for DriscoPlex™ PE 3408 pipe filled with water at 73°F (23°C). Spacing will vary for different temperature and for different fluids in the pipe.

## BURIED PIPE DESIGN

The design of a subsurface pipe installation is based on the interaction between, the pipe and the surrounding soil. The stiffness of pipe and soil relative to each other determine pipe and embedment design and control overall performance for an application.

Embedment and static and dynamic loads from the surface cause vertical and horizontal pipe deflection. Pipe deflection mobilizes passive resistance forces from the embedment soil, which in turn limits horizontal deflection and balances the vertical load. Greater passive resistance is mobilized with stiffer surrounding soil, so less deflection occurs. Most polyethylene pipe should be considered flexible because the pipe's contribution to resisting deflection is usually less than that of the surrounding soil.

With polyethylene pipe it is important to check each application to ensure the adequacy of the installed design, including both pipe and embedment soils. Performance Pipe publishes extensive design information on buried pipes in the *Performance Pipe engineering Manual*, PP-900 that may be applied to both rigid and flexible pipes. Because of complexities in soil-pipe interaction, engaging a qualified engineer for the determination of buried pipe design and for achieving specific project requirements is strongly recommended.

The design guidelines in the *Performance Pipe Engineering Manual*, PP-900 are contingent upon the pipe being installed according to recognized industry standards for flexible pipe installation including as ASTM D-2321 *Standard Practice for underground Installation of Thermoplastic Pipe for Sewers and Other Gravity-Flow applications*, and ASTM D-2774 *Standard Practice for Underground Installation of Thermoplastic Pressure Pipe*.

### **Groundwater Flotation**

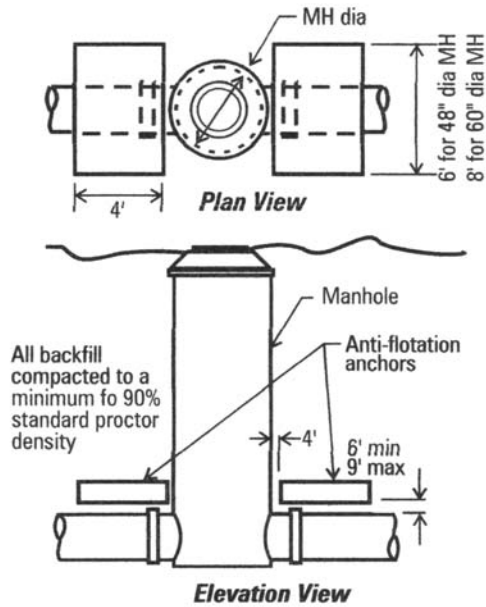
A buried pipe or manhole may be subject to flotation from high groundwater levels around the pipe. While lightweight polyethylene is easily handled and installed, its lesser weight compared to that of metal or concrete pipe, compels design evaluation of groundwater flotation effects.

A quick rule of thumb is that when buried in common saturated soil

(about 120 lb/ft<sup>3</sup>) with at least one and one half pipe diameters of cover, pipe is generally not subject to groundwater flotation. However, groundwater flotation should be checked if the pipe is buried in lighter soils, or with lesser cover, or the pipe frequently has little liquid flow during high groundwater conditions.

Compared to pipe, manholes are less resistant to groundwater flotation because the manhole riser eliminates the soil prism load that exists above buried pipe. Under some groundwater conditions, the frictional resistance of the soil surrounding the manhole riser, and the soil prism load over the manhole stub-outs may not be adequate to prevent flotation; so anti-flotation anchoring may be required.

Anti-flotation anchor slabs are reinforced concrete slabs that are placed above the manhole stub-outs. See Figure 4. The anchors provide additional weight to counteract buoyant forces against the manhole base. Anti-flotation anchors are installed beside the manhole shaft above the manhole stub-outs. Depending upon manhole and stubout design, anti-flotation anchoring may employ a ring around the manhole shaft above or below the stubouts, and then casting a concrete anti-flotation collar above the ring (not illustrated). Anti-flotation anchor design information is available in the *Performance Pipe Engineering Manual*, PP-900 and the *HDPE Manhole Reference Guide*, PP-902 and is not reproduced in this handbook.

**Figure 4 Anti-Flotation Anchor Slab Installation**

## WATER ENVIRONMENT DESIGN CONSIDERATIONS

Water environment applications include any installation in a predominantly water environment, such as outfalls and intakes, river, lake, and stream crossings, floating and submerged pipelines, and wetland and marsh area installations. Further, applications such as sliplining may require design consideration for external hydrostatic loads if the water table rises above the liner. Water environment design considerations include external hydraulic pressure, submergence weighting, and flotation at or above the surface.

### External Hydraulic Pressure

For the purposes of this discussion, unrestrained DriscoPlex™ OD controlled polyethylene pipes are freestanding pipes that are not encapsulated in backfill or encased in grout. When installed where continuous or occasional submergence may occur, such pipes may be caused to collapse if the net external hydraulic pressure exceeds the flattening resistance of the pipe.

Flattening resistance should be considered for applications such as pipes carrying gases, pipes partially full of liquids, and any application where the internal pressure is less than the static external hydraulic load.

Flattening resistance usually is not a consideration for outfall and intake lines where the end of the pipe is open to the external water environment, or for water or wastewater lines crossing under rivers, streams or lakes. Open ended lines will be pressure balanced, and the static head in a full pipe crossing a water body will usually be the same or higher than the water height above the pipeline.

**Table 14 External Pressure Resistances, psi**

<i>Values are for 3% oval pipe and include a 2.0 safety factor. Multiply psi by 2.307 to obtain feet of water.</i>							
Service Temp., °F	Pipe DR	External Pressure Resistance, psi					
		50 y	10 y	1 y	1000 h	100 h	10 h
40	9	72.8	81.7	98.1	113.0	132.2	148.5
	11	37.3	41.8	50.2	57.8	67.7	76.0
	13.5	19.1	21.4	25.7	29.6	34.6	38.9
	17	9.1	10.2	12.3	14.4	16.5	18.6
	21	4.7	5.2	6.3	7.2	8.5	9.5
	26	2.4	2.7	3.2	3.7	4.3	4.9
	32.5	1.2	1.3	1.6	1.9	2.2	2.4
60	9	55.7	62.4	75.0	86.4	101.1	113.5
	11	28.5	31.9	38.4	44.2	51.7	58.1
	13.5	14.6	16.3	19.7	22.6	26.5	29.8
	17	7.0	7.8	9.4	10.8	12.6	14.2
	21	3.6	4.0	4.8	5.5	6.5	7.3
	26	1.8	2.0	2.5	2.8	3.3	3.7

<i>Values are for 3% oval pipe and include a 2.0 safety factor. Multiply psi by 2.307 to obtain feet of water.</i>							
Service Temp., °F	Pipe DR	External Pressure Resistance, psi					
		50 y	10 y	1 y	1000 h	100 h	10 h
	32.5	0.9	1.0	1.2	1.4	1.7	1.9
73	9	52.6	58.8	70.7	81.3	95.3	107.0
	11	26.9	30.1	36.2	41.6	48.8	54.8
	13.5	13.8	15.4	18.5	21.3	25.0	28.1
	17	6.6	7.4	8.8	10.2	11.9	13.4
	21	3.4	3.8	4.5	5.2	6.1	6.8
	26	1.7	1.9	2.3	2.7	3.1	3.5
	32.5	0.9	1.0	1.2	1.3	1.6	1.8
100	9	42.8	48.0	57.7	66.4	77.8	87.3
	11	21.9	24.6	29.5	34.0	39.8	44.7
	13.5	11.2	12.6	15.1	17.4	20.4	22.9
	17	5.4	6.0	7.2	8.3	9.7	10.9
	21	2.7	3.1	3.7	4.3	5.0	5.6
	26	1.4	1.6	1.9	2.2	2.5	2.9
	32.5	0.7	0.8	0.9	1.1	1.3	1.4
120	9	27.9	31.3	37.6	43.2	50.6	56.8
	11	14.3	16.0	19.3	22.1	25.9	29.1
	13.5	7.3	8.2	9.9	11.3	13.3	14.9
	17	3.5	3.9	4.7	5.4	6.3	7.1
	21	1.8	2.0	2.4	2.8	3.2	3.6
	26	0.9	1.0	1.2	1.4	1.7	1.9
	32.5	0.5	0.5	0.6	0.7	0.8	0.9

### ***Submergence Weighting***

DriscoPlex™ polyethylene materials are lighter than water and pipe will float slightly above the surface when filled with water. Submerged pipe must be ballasted to keep it submerged.

Ballast weight design considers the weight and volume of the pipe, pipe contents, and ballast, and the environmental conditions. ***Ballast weights are usually spaced every to 10-15 feet to avoid excessive pipe bending stresses during and after installation.***

**STEP BY STEP BALLAST DESIGN**

See Performance Pipe Bulletins PP-152 and PP-153 for pipe dimensions and weights.

**Step 1**

Determine the volume of liquid displaced and buoyancy for one foot of pipe:

$$V_P = \frac{\pi D^2}{576}$$

$$B_P = V_P K \omega_{LO}$$

Where

- $V_P$  = displaced volume of pipe, ft<sup>3</sup>/ft
- $D$  = pipe outside diameter, in
- $B_P$  = buoyancy of pipe, lb/ft
- $K$  = environmental multiplier (Table 15)
- $\omega_{LO}$  = specific weight of the liquid outside the pipe, lb/ft<sup>3</sup>

The environmental multiplier,  $K$ , compensates for the effects of tidal flows and currents. Unless neutral buoyancy is desired,  $K$  should be greater than 1.0.

**Table 15 Environmental Multiplier,  $K$**

<i>Underwater Environment</i>	<i>K</i>
Neutral buoyancy	1.0
Lakes, ponds, slow moving streams or rivers, low currents and tidal actions	1.3
Significant stream or river currents or tidal flows	1.5

Table 16 presents specific weights for various liquids. For other liquids and slurries the formula below may be used to calculate a specific weight when the specific gravity of the liquid is known. For gasses (air, gas, carbon dioxide, etc.) in the pipe, assume a specific gravity of zero relative to water.

$$\omega_L = 62.4 S_L$$

Where

$\omega_L$  = specific weight of liquid  
 $S_L$  = specific gravity of liquid

**Table 16 Specific Gravities Weights of Liquids at 60°F (15°C)**

<i>Liquid</i>	<i>Specific Gravity, <math>S_L</math></i>	<i>Specific Weight, <math>\omega_L</math></i>
Gasoline	0.68	42.5
Kerosene	0.80	50.2
Crude Oil	0.86	53.1
Fresh water	1.00	62.4
Seawater	1.026	64.0
Brine, 6% NaCl	1.044	65.1
Brine, 12% NaCl	1.088	67.8
Brine, 18% NaCl	1.135	70.8
Brine, 24% NaCl	1.184	73.8
Brine, 6% CaCl	1.050	65.52
Brine, 12% CaCl	1.105	68.95
Brine, 18% CaCl	1.162	72.51
Brine, 24% CaCl	1.223	76.32
Brine, 30% CaCl	1.287	80.35

**Step 2**

Determine negative buoyancy (pipe weight and pipe contents weight):

$$V_B = \frac{\pi d^2}{576}$$

$$B_N = w_P + (V_B \omega_{LI})$$

Where

$V_B$  = pipe bore volume, ft<sup>3</sup>/ft  
 $d$  = pipe inside diameter, in  
 $B_N$  = negative buoyancy, lb/ft  
 $w_P$  = pipe weight, lb/ft  
 $\omega_{LI}$  = specific weight of the liquid inside the pipe, lb/ft<sup>3</sup>

**Step 3**

Determine the weight of the submerged ballast:

$$W_{BS} = B_P - B_N$$

Where

$W_{BS}$  = weight of submerged ballast, lb/ft

**Step 4**

The designer must choose an appropriate ballast weight material (concrete, steel, etc.). For the chosen ballast weight material, determine the dry land weight required.

$$W_{BD} = \frac{L W_{BS} \omega_B}{(\omega_B - K \omega_{LO})}$$

Where

$W_{BD}$  = weight of dry ballast, lb

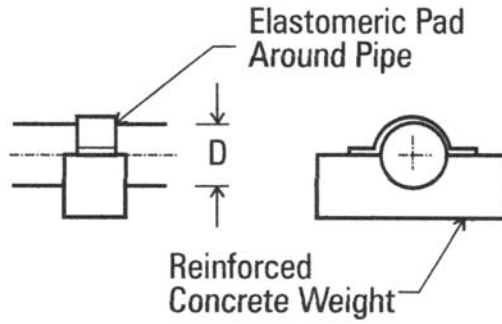
$L$  = ballast weight spacing, ft

$\omega_B$  = specific weight of ballast material. lb/ft<sup>3</sup>

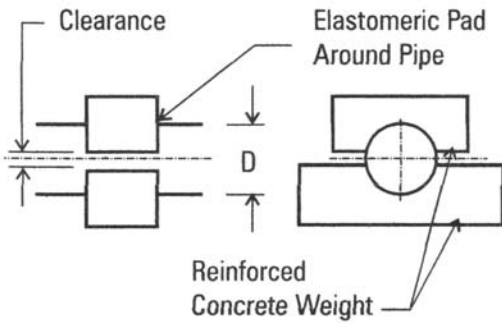
**WEIGHT SHAPES**

Submergence weights are frequently made of reinforced concrete, which allows considerable flexibility of shape design. Weights are typically formed in two or more sections that clamp around the pipe over an elastomeric padding material. There should be clearance between the sections, so when clamped onto the pipe, the sections do not slide along the pipe. In general, weights are flat bottom, and bottom heavy. This prevents rolling from crosscurrent conditions. Fasteners securing the weight sections together must be resistant to the marine environment.

**Figure 5 Concrete Ballast Weight**



**Figure 6 Concrete Ballast Weight**



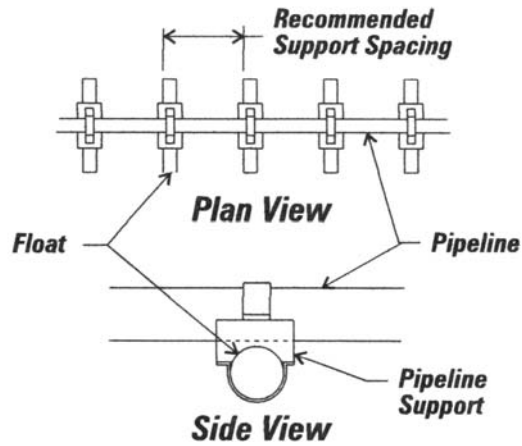
***Floating Pipelines***

Pipelines for dredging or for discharging slurries into impoundments may be required to float on or above the surface. Polyethylene is about 4.5% lighter than water, so the pipe will float when filled with water. However, liquid slurries may be heavy enough to sink the line.

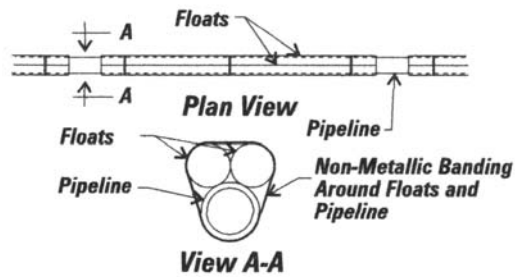
When the pipeline is supported above the surface, the floats must support their own weight and the weight of the pipeline and its contents.

When floated at the surface, the displacement of the pipeline in the water reduces floatation requirements. Figures 7 and 8 illustrate float attachment methods.

**Figure 7 Flotation Above the Surface**



**Figure 8 Flotation On the Surface**



**POLYETHYLENE PIPE FOR FLOTATION**

DriscoPlex™ OD controlled pipe may be used for flotation to support pipelines above the water or at the surface. Typically, floats are pipe lengths that are capped on the ends. Floats can be filled with lightweight foam so that physical damage will not allow the float to fill with water and impair its ability to support a load.

Float sizing is an iterative process because the float must support itself as well as the load. The first step is to determine the load, and choose an initial size for the float.

**Step 1. Load Determination**

The supported load is the weight of the pipeline and its contents plus the weight of the float and the structure for attaching the float to the pipeline. If the float is foam-filled, the weight of the foam must also be included.

$$P = W_P + W_C + W_S + W_F + W_M$$

Where

- P = supported load, lb/ft
- $W_P$  = weight of pipeline, lb/ft
- $W_C$  = weight of pipeline contents, lb/ft
- $W_S$  = weight of float attachment structure, lb
- $W_F$  = weight of float, lb/ft (Table 17)
- $W_M$  = weight of foam fill, lb/ft

$$W_M = V_F M_M$$

- $V_F$  = float internal volume, ft<sup>3</sup>/ft (Table 17)
- $M_M$  = density of foam fill, lb/ft<sup>3</sup>

Thermoplastic foams typically weigh 2 to 3 lb/ft<sup>3</sup>.

Float spacing should not exceed maximum support spacing intervals. See Table 13.

**Table 17 Polyethylene Float Properties†**

Nominal Size	Float Diameter, d, in	Float Weight, W <sub>F</sub> , lb/ft	Float Buoyancy, B, lb/ft	Internal Volume, V <sub>F</sub> , ft <sup>3</sup> /ft
4	4.500	0.83	6.9	0.097
6	6.625	1.80	14.9	0.211
8	8.625	3.05	25.3	0.357
10	10.750	4.75	39.3	0.555
12	12.750	6.67	55.3	0.781
14	14.000	8.05	66.7	0.941
16	16.000	10.50	87.1	1.230
18	18.000	13.30	110	1.556
20	20.000	16.41	136	1.921
22	22.000	19.86	165	2.325
24	24.000	23.62	196	2.767
26	26.000	27.74	230	3.247
28	28.000	32.19	267	3.766
30	30.000	36.93	306	4.323
32	32.000	42.04	349	4.919
34	34.000	47.43	393	5.553
36	36.000	53.20	441	6.225

† Properties based on black HDPE material (0.955 g/cm<sup>3</sup> density) and DR 32.5 pipe.

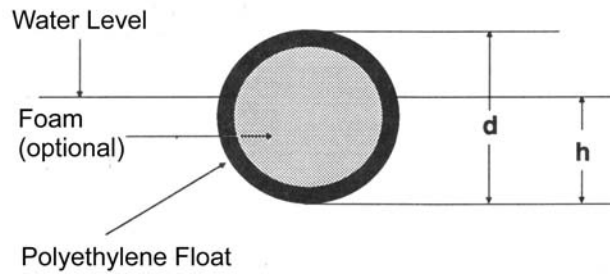
**Step 2. Float Submergence Percentage**

The percent submergence is the percent of the float that is below the water level as illustrated in Figure 9.

$$\% \text{ Submergence} = 100 \frac{h}{d}$$

Where

- h = pipe submergence below water level, in
- d = pipe diameter, in (Table 17)

**Figure 9 Float Submergence**

The designer should choose an appropriate percent submergence and submergence margin. For the floats in Table 17, submergence margins are shown in Table 18. If the percent submergence is too high, point-loaded floats may deflect at the load center and be more deeply submerged at the load center compared to unloaded areas.

**Table 18 Submergence Margin**

<i>% Submergence</i>	<i>Submergence Margin</i>
55%	2
43%	3
37%	4

**Step 3. Float Support Capacity**

Determine the float buoyancy,  $B$ , from Table 17 for the initial float size. Then determine the submergence factor,  $f_s$ , from Table 19.

**Table 19 Submergence Factor,  $f_s$** 

<i>Submergence</i>		<i>Submergence</i>		<i>Submergence</i>		<i>Submergence</i>	
<i>%</i>	<i>Factor, <math>f_s</math></i>	<i>%</i>	<i>Factor, <math>f_s</math></i>	<i>%</i>	<i>Factor, <math>f_s</math></i>	<i>%</i>	<i>Factor, <math>f_s</math></i>
5	0.019	30	0.252	55	0.564	80	0.858
10	0.052	35	0.312	60	0.623	85	0.906
15	0.094	40	0.377	65	.0688	90	0.948
20	0.142	45	0.436	70	0.748	95	0.981
25	0.196	50	0.500	75	0.804	100	1.000

Determine the load supporting capacity of the float,  $P_F$ .

$$P_F = f_S B$$

Where

- $P_F$  = float load supporting capacity, lb/ft
- $f_S$  = submergence factor from Table 19
- $B$  = buoyancy from Table 17

#### **Step 4. Compare Float Support Capacity to Load**

The support capacity of the float must equal or exceed the load it is to support.

$$P_F \geq P$$

If the load,  $P$ , is greater than the float support capacity,  $P_F$ , choose a larger float and repeat Steps 1, 2 and 3. If the float support capacity,  $P_F$ , is significantly greater than the load,  $P$ , a smaller float may be adequate.

#### **Step 5. Check Actual Float Submergence**

Once the proper float size has been determined, check the actual float submergence.

$$f_{SA} = \frac{P}{B}$$

Where

- $f_{SA}$  = actual float submergence factor

The actual float submergence factor,  $f_{SA}$ , may be compared to the values in Table 19 to determine the approximate percent submergence.

## **RECEIVING AND HANDLING**

### ***Receiving Inspection***

There is no substitute for visually inspecting an incoming shipment to verify that the paperwork accurately describes the load. Performance Pipe products are identified by markings on each individual product. These markings should be checked against the Packing List. The number of packages and their descriptions should be checked against

the Bill of Lading.

The delivering truck driver will ask the person receiving the shipment to sign the Bill of Lading, and acknowledge that the load was received in good condition. **Any damage, missing packages, etc., should be noted on the bill of lading at that time** and reported to Performance Pipe immediately.

### ***Unloading***

**Unloading and handling must be performed safely. Unsafe unloading or handling can result in death, injury or damage. Keep unnecessary persons away from the area while unloading.**

***Observe the unloading and handling instructions that are supplied with the load and available from the driver.***

#### **UNLOADING SITE REQUIREMENTS**

**Before unloading the shipment, there must be adequate, level space to unload the shipment. The truck should be on level ground with the parking brake set and the wheels chocked. Unloading equipment must be capable of safely lifting and moving pipe, fittings, fabrications or other components.**

Silo packs and other palletized packages should be unloaded from the side with a forklift. Non-palletized pipe, fittings, fabrications, manholes, tanks, or other components should be unloaded from above with lifting equipment and wide web slings, or from the side with a forklift.

**Pipe must not be rolled or pushed off the truck. Pipe, fittings, fabrications, tanks, manholes, and other components must not be pushed or dumped off the truck, or dropped.**

#### **HANDLING EQUIPMENT**

**Equipment must be appropriate for lifting and handling and have adequate rated capacity to lift and move components from the truck to temporary storage. Safe handling and operating procedures must be followed.**

Equipment such as a forklift, a crane, a side boom tractor, or an extension boom crane is used for unloading.

When using a forklift, or forklift attachments on equipment such as

articulated loaders or bucket loaders, lifting capacity must be adequate at the load center on the forks. Forklift equipment is rated for a maximum lifting capacity at a distance from the back of the forks. (See Figure 10.) If the weight-center of the load is farther out on the forks, lifting capacity is reduced.

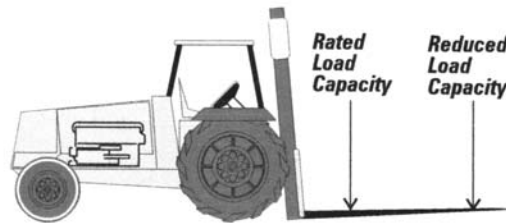
Before lifting or transporting the load, forks should be spread as wide apart as practical, forks should extend completely under the load, and the load should be as far back on the forks as possible.

**During transport, a load on forks that are too short or too close together, or a load too far out on the forks, may become unstable and pitch forward or to the side, and result in injury or damage.**

Lifting equipment such as cranes, extension boom cranes, and side boom tractors, should be hooked to wide web choker slings that are secured around the load or to lifting lugs on the component. Only wide web slings should be used. Wire rope slings and chains can damage components, and should not be used. Spreader bars should be used when lifting pipe or components longer than 20'.

**Before use, inspect slings and lifting equipment. Equipment with wear or damage that impairs function or load capacity should not be used.**

**Figure 10 Forklift Load Capacity**



### ***Pre-Installation Storage***

The storage area should provide protection against physical damage to components, be of sufficient size to accommodate piping components, to allow room for handling equipment to get around, and have a

relatively smooth, level surface free of stones, debris, or other material that could damage pipe or components, or interfere with handling.

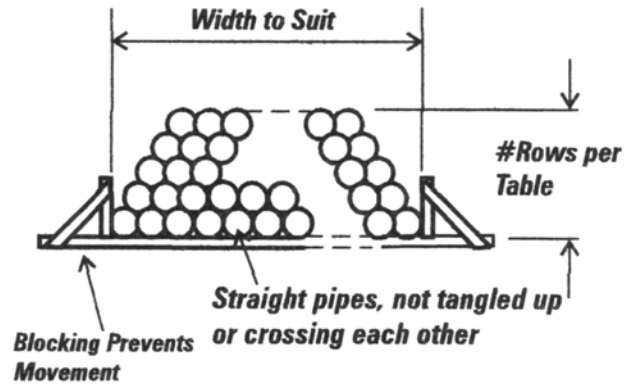
### PIPE STACKING HEIGHTS

Coiled pipe is best stored as received in silo packs. Individual coils may be removed from the silo pack without disturbing the stability of the package.

Pipe received in bulk packs or strip load packs should be stored in the same package. If the storage site is flat and level, bulk packs or strip load packs may be stacked evenly upon each other to an overall height of about 6'. For less flat or less level terrain, limit stacking height to about 4'.

**Before removing individual pipe lengths from bulk packs or strip load packs, the pack must be removed from the storage stack and placed on the ground.**

Figure 11 Loose Pipe Storage



Individual pipes may be stacked in rows. Pipes should be laid straight, not crossing over or entangled with each other. **The base row must be blocked to prevent sideways movement or shifting.** (See Figure 11 and Table 20.) Loose pipe should be placed on wooden dunnage at least 4 inches wide, and evenly spaced at intervals of about 6 feet

beginning about 2 feet from the end of the pipe. The interior of stored pipe should be kept free of debris and other foreign matter.

**Table 20 Suggested Jobsite Loose Storage Stacking Heights**

Nominal Size	Stacking Height, rows	
	DR Above 17	DR 17 & Below
4	15	12
5	12	10
6	10	8
8	8	6
10	6	5
12	5	4
14	5	4
16	4	3
18	4	3
20	3	3
22	3	2
24	3	2
26	3	2
28	2	2
30	2	2
32	2	2
36	2	1
42	1	1
48	1	1
54	1	1

Suggested stacking heights based on 6' for level terrain and 4' for less level terrain.

### ***Cold Weather Handling***

Temperatures near or below freezing will affect polyethylene pipe by increasing stiffness, vulnerability to impact damage and sensitivity to suddenly applied stress especially when cutting. Polyethylene pipe will be more difficult to uncoil or field bend in cold weather.

*Significant impact or shock loads against a polyethylene pipe that is at freezing or lower temperatures can fracture the pipe.*

- ***Do not drop pipe. Do not allow pipe to fall off the truck or into the trench.***
- ***Do not strike the pipe with handling equipment, tools or other objects.***
- ***Do not drag pipe lengths at speeds where bouncing against the surface may cause impact damage.***

Pipe should be firmly supported on both sides when cutting with a handsaw. Low temperature can cause the pipe to fracture at the cut if bending stress is applied.

Ice, snow, and rain are not harmful to the material, but may make storage areas more troublesome for handling equipment and personnel. Unsure footing and traction require greater care and caution to prevent damage or injury.

## **JOINING & CONNECTIONS**

For satisfactory material and product performance, system designs and installation methods rely on appropriate, properly made connections. An inadequate or improperly made field joint may cause installation delays, may disable or impair system operations, or may create hazardous conditions.

DriscoPlex™ OD controlled piping products are connected using heat fusion, electrofusion, and mechanical methods such as MJ Adapters, flanges, and compression couplings. Joining and connection methods will vary depending upon requirements for internal or external pressure, leak tightness, restraint against longitudinal movement (thrust load capacity), gasketing requirements, construction and installation requirements, and the product.

**Warning – Connection design limitations and manufacturers joining procedures must be observed. Otherwise, the connection or products adjacent to the connection may leak or fail which may result in property damage, or hazards to persons.**

**Correctly made fusion joints do not leak. Leakage at a joint or connection may immediately precede catastrophic failure. Never approach or attempt to repair or stop leaks while piping is pressurized. Always depressurize piping before making repairs.**

Always use the tools and components required to construct and install joints in accordance with manufacturer's recommendations and instructions. However, field connections are controlled by, and are the responsibility of the field installer.

### **General Procedures**

All field connection methods and procedures require that the component ends to be connected must be clean, dry, and free of detrimental surface defects before the connection is made. Contamination and unsuitable surface conditions usually produce an unsatisfactory connection. Gasketed joints require appropriate lubrication.

### **CLEANING**

Before joining, and before any special surface preparation, surfaces must be clean and dry. General dust and light soil may be removed by wiping the surfaces with clean, dry, lint free cloths. Heavier soil may be washed or scrubbed off with soap and water solutions, followed by thorough rinsing with clear water, and drying with dry, clean, lint-free cloths.

**Before using chemical cleaning solvents, the user should know the potential risks and hazards to persons, and appropriate safety precautions must be taken. Chemical solvents may be hazardous substances that may require special handling and personal protective equipment.**

The manufacturer's instructions for use, and the material safety data sheet (MSDS) for the chemical should be consulted for information on risks to persons and for safe handling and use procedures. Some solvents may leave a residue on the pipe. Information on chemical compatibility with polyethylene may be found in the *Performance Pipe*

### **CUTTING DRISCOPLEX™ OD CONTROLLED PIPE**

Joining methods for plain end pipe require square-cut ends. Pipe cutting is accomplished with guillotine shears, run-around cutters and saws. Before cutting, provide firm support on both sides.

Guillotine shears are commonly available for 2" and smaller pipe and tubing, and may incorporate a ratcheting mechanism to drive the blade through the pipe. Run-around pipe cutters are equipped with deep, narrow cutter wheels, and because of wall thickness, are usually limited to about 4" pipe. Care should be taken to avoid cutting a spiral groove around the pipe. Guillotine and run-around cutters provide a clean cut without chips.

For larger diameters, handsaws and chain saws are used. Coarse tooth handsaws provide greater chip clearance between the teeth, and maintain a clean blade when cutting. Chain saws are usually operated without chain lubrication because chain oil contamination will need to be removed from the pipe. Bucking spikes should be removed.

Saws will produce chips that must be removed from the pipe bore and cleared from the jobsite. Pipe ends may require deburring.

### **CUTTING BRANCH OUTLET HOLES**

With the exception of self-tapping saddle tees, hole cutting will be required for field installed side outlet fittings. Commercial hole saws for metals are generally unsatisfactory for polyethylene because they do not provide adequate chip clearance, and may not be deep enough for the wall thickness. Polyethylene pipe hole saws are deep shell cutters with very few teeth, large chip clearance, and inside relief to retain the coupon. Polyethylene pipe joining equipment manufacturers should be contacted for additional information on hole saws.

When cutting, hole saws should be withdrawn frequently to clear the chips. Powered hole saws should be operated at relatively low speeds to avoid overheating and melting the material.

### ***Heat Fusion Joining***

Refer to Performance Pipe *Heat Fusion Joining Procedures and*

*Qualification Guide*, Bulletin PP-750 for recommended heat fusion joining procedures. This handbook does not provide heat fusion joining procedures.

**Performance Pipe Fusion Joining Procedures should be reviewed before making heat fusion joints, and should be observed when making heat fusion joints with DriscoPlex™ OD controlled polyethylene-piping products.**

Heat fusion joining is a process where mating surfaces are prepared for joining, heated until molten, joined together and cooled under pressure. All fusion procedures require appropriate surface preparation tools, alignment tools, and temperature controlled heating irons with properly shaped, non-stick heater faces. *An open flame cannot be used for heating because it oxidizes the surface and prevents bonding.* During joining, all heat fusion procedures require the mating components to be moved several inches apart to accommodate surface preparation and surface heating tools.

Butt fusion joins plain end pipe or fittings end to end. Saddle fusion joins a curved base, branch outlet to the side of a pipe. Socket fusion joins a male pipe or fitting end into a female socket fitting. Heat fusion joining procedures do not add material to the joint; that is, no welding rods, adhesives, or cements are used.

Heat fusion joints made between appropriate products using appropriate equipment and recommended procedures are fully restrained, permanent joints. That is, correctly made heat fusion joints may be expected to last the life of the system and withstand thrust loads equal to the strength of the pipe without adding external restraint or thrust blocking.

See *Cautions and Notices* at the beginning of this handbook.

## BUTT FUSION

Figure 12 Butt Fusion Bead – Visual Inspection Guidelines

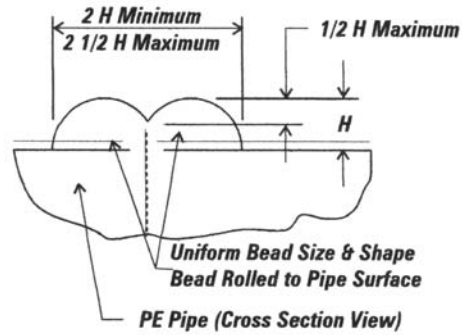


Table 21 Approximate Butt Fusion Joining Rates

Pipe Size, IPS	Approximate Number of Fusions per Day
≤ 10"	15 – 40
10" – 18"	10 – 24
18" – 24"	6 – 16
24" – 36"	5 – 15
36" – 48"	4 – 10
54"	3 – 6

### BEAD REMOVAL

Butt fusion produces a double-roll melt bead on the inside and the outside of the pipe. External beads typically do not interfere with clearance during sliplining or insertion renewal, and internal beads have little or no effect on flow. Bead removal is time consuming, and if done improperly, may compromise long-term performance. **The fusion joint**

**must be completely cooled to ambient temperature – inside and out – before bead removal. If removed, the bead is removed down to, or just above the pipe's surface, never below it.** Polyethylene shrinks as it cools from the molten state. ***Removing the bead before complete cooling will result in a notch at the fusion that will increase the potential for failure at the fusion joint.***

External beads are removed with run-around cutting tools, which are forced into the bead; then drawn around the pipe. Internal beads may be removed with remote controlled cutters, or length-by-length with a cutter fitted to a long pole. Manual or power tools such as chisels or planers may also be used, but care must be taken not to cut into the pipe surface.

#### **BUTT FUSION IN THE FIELD**

Set-up time is minimized when pipe lengths are fed through the machine and joined into long strings.

***Caution – Dragging pipe strings along the ground at speeds above a walking pace can damage the pipe, especially in cold weather.***

Many Performance Pipe Distributors provide fusion joining services, and rent heat fusion equipment and may be consulted about equipment rental and fusion joining services. Performance Pipe does not rent fusion equipment or provide contract field fusion joining services.

Fusion procedure and equipment settings should be verified for the conditions at the jobsite. Verification can include ensuring operator training and qualification, testing for fusion quality, and recording fusion procedure and equipment operation.

The fusion technician should be able to document training and demonstrate proficiency with the fusion procedure, equipment and products being fused. Some fusion equipment may be connected to devices (such as a data logger) that can record equipment settings and operation during fusion. When used in combination with appropriate field fusion verification tests, data logger information can provide a record of field fusion quality.

#### **SADDLE (SIDEWALL) AND SOCKET FUSION**

Saddle (sidewall) fusion is used to connect PE service and branch lines to PE mains. Socket fusion is used to connect smaller sizes typically for

geothermal or force main applications. Refer to Performance Pipe Bulletin PP-750 for saddle and socket fusion procedures.

### ***Electrofusion***

Electrofusion is a heat fusion process where a coupling or saddle fitting contains an integral heating source. After surface preparation, the fitting is installed on the pipe and the heating source is energized. During heating, the fitting and pipe materials melt, expand and fuse together. Heating and cooling cycles are automatically controlled.

Electrofusion is the only heat fusion procedure that does not require longitudinal movement of one of the joint surfaces. It is frequently used where both pipes are constrained, such as for repairs or tie-in joints in the trench. Joints made between dissimilar polyethylene brands or grades are also made using electrofusion, as the procedure accommodates polyethylene materials with different melt flow rates. Electrofusion equipment and component manufacturers should be contacted for specific information.

### ***Extrusion Welding***

Extrusion welding employs a small handheld extruder that feeds molten PE onto pre-heated, specially prepared PE surfaces. Preparation requires removing a thin layer of material from the surfaces of the parts being welded and cleaning, scraping, planing or beveling. The extrusion gun preheats the surfaces; then feeds a molten polyethylene bead into the prepared joint area.

The ideal environment for extrusion welding is in a plant or shop area where the requisite conditions for good welding are present, that is, cleanliness, properly trained operators and the special jigs and tools that are required for the extrusion welding process. Using prescribed procedures, welded joints produced under ideal conditions can develop up to 70% the tensile strength of the base material. Field joints usually require special care and highly trained operators to produce similar quality joints.

Typically, extrusion welding is used for shop fabrication of low pressure or non-pressure structures, such as manholes, tanks, very large fittings, dual containment systems and odor control structures.

**Extrusion welding is not a substitute for butt, saddle or socket**

**fusion and is not to be used to join or repair pressure pipe or fittings.** Extrusion welding is not the same as Hot Gas (Hot Air) Welding.

### ***Hot Gas Welding***

**Hot gas (hot air) welding is not to be used with Performance Pipe polyethylene piping products.**

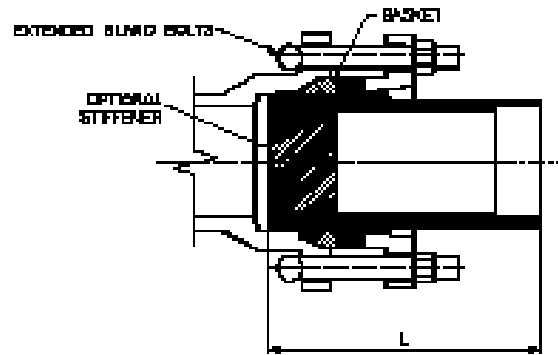
Hot air (hot gas) welding uses hot air to melt a polyethylene “welding rod” and join the surfaces. It is usually limited to use with low molecular weight, high melt flow rate polyethylene materials. However, Performance Pipe polyethylene pipe products are made from stress-rated, high molecular weight, low melt flow rate polyethylene materials. These high quality polyethylene materials do not melt or flow easily. Under good conditions, hot gas weld strength is typically less than 15% of the parent material’s strength, thus, hot gas welding is unsuitable for use with all Performance Pipe polyethylene piping products.

### ***Mechanical Connections***

Mechanical connections are used to connect polyethylene components to themselves or to other pipe materials or components. For MJ (mechanical joint) and flange connections, an adapter is butt fused to PE pipe; then the adapter is connected to the mating component. Other mechanical connectors connect directly to plain-end PE pipe. Compression couplings require a stiffener in the pipe ID for pullout resistance. Insert fittings for small pipe and tubing fit into the pipe ID, and use a compression sleeve on the OD.

#### **DRISCOPLEX™ MJ ADAPTER**

DriscoPlex™ MJ Adapters are manufactured in standard IPS and DIPS sizes for connecting IPS-sized or DIPS-sized polyethylene pipe to mechanical joint pipe, fittings and appurtenances that meet AWWA C111/ANSI A21.11. DriscoPlex™ MJ Adapters seal against leakage and restrain against pullout. No additional external clamps or tie rod devices are required.

**Figure 13 DriscoPlex™ MJ Adapter with Optional Stiffener**

DriscoPlex™ MJ Adapters can be provided as a complete kit including the MJ adapter with a stainless steel stiffener, extended gland bolts and nuts, gland and gasket. The internal stiffener is optional for some sizes.

### MJ ADAPTER ASSEMBLY

#### Alignment

When fitting up, DriscoPlex™ MJ Adapters must be aligned straight into the mating hub before tightening the gland bolts. Do not draw the MJ Adapter into alignment by tightening the gland bolts. When fitted-up with hand-tight gland bolt nuts, the gap between the socket hub flange and gland bolt flange should be the same all around the joint. The difference between the widest gap and the narrowest gap should not be more than 3/16" (5 mm). (The actual gap measurement can be 1" (25 mm) or more.)

Because polyethylene pipe is flexible, it is not necessary to allow for angular misalignment at MJ Adapter connections.

#### Assembly

1. Inspect the MJ Adapter kit to be sure all components are present in the correct quantities. The DriscoPlex™ MJ Adapter kit includes

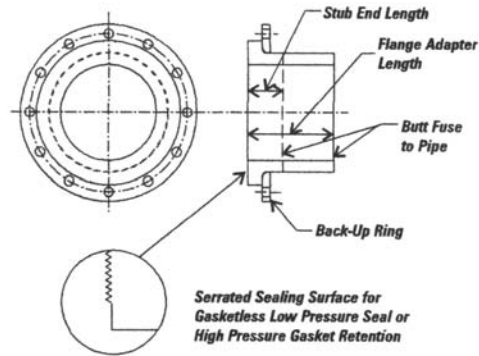
- the MJ Adapter with the stiffener, gasket, gland, extended-length gland bolts and nuts.
2. Fit the gland over the fusion end of the MJ adapter (the long end from the rib) and slide it against the rib. The gland projection fits against the rib. See the illustration above.
  3. Join the MJ Adapter to polyethylene pipe. Butt fusion using *Performance Pipe Recommended Fusion Procedures*, Bulletin PP-750, is the preferred joining method. When the gland is against the MJ Adapter rib, the butt fusion end of the MJ Adapter is long enough to be clamped in a butt fusion machine and make the butt fusion. Allow the fusion to cool properly before handling.
  4. The mating mechanical joint socket hub and the end of the MJ Adapter must be clean. Thoroughly remove all rust and foreign material from the inside of the socket hub. Wipe the mating end of the MJ Adapter with a clean, dry cloth to remove all dirt and foreign material.
  5. Install the gasket on MJ Adapter. Seat the thick section of the gasket against the MJ Adapter rib.
  6. Lubricate the gasket, the end of the MJ adapter, and the inside of the socket hub with an approved pipe lubricant meeting AWWA C111. *Do not use soapy water.*
  7. Insert the MJ Adapter into the socket hub. Make sure it is evenly and completely seated in the socket hub. *The MJ Adapter and the socket hub must be aligned straight into each other. See "Alignment" above.*
  8. Insert the gland bolts, and run the nuts up finger-tight.
  9. Tighten the gland bolts evenly to 75 – 90 ft-lb (102 – 122 n-m). Tighten in torque increments of about 15 – 20 ft-lb (20 – 27 n-m) each and follow a tightening pattern – tighten the bottom bolt; then the top bolt; then the bolts to either side, and finally the remaining bolts in a crossing pattern from one side to the other. At one torque increment, tighten all bolts completely through the pattern before going up to the next higher torque increment and tightening through the pattern. *Tightening with torque-measuring wrenches is strongly recommended.* During tightening, maintain approximately the same gap between the gland and the face of the socket hub flange at all points around the joint.

### Flange Connection

Flanged joints are made using a DriscoPlex™ Flange Adapter that is butt fused to pipe. A back-up ring is fitted behind the flange adapter sealing surface flange and bolted to the mating flange. DriscoPlex™ Flange Adapters have a serrated sealing surface. At lower pressure, typically 80 psi or less, a gasket is usually not required. At greater pressure, the serrations help hold the gasket. See Figure 14.

Standard back-up rings are Class 125 for 160 psi and lower pressure ratings, or Class 150 for higher pressures. Back-up ring materials are ductile iron, steel, primer-coated steel; epoxy coated steel, or stainless steel. Fiberglass is also available. In below ground service, coatings and cathodic protection may be needed to protect metal back-up rings from corrosion. One edge of the back-up ring bore must be radiused or chamfered. This edge fits against the back of the sealing surface flange.

**Figure 14 Flange Adapter and Back-Up Ring**

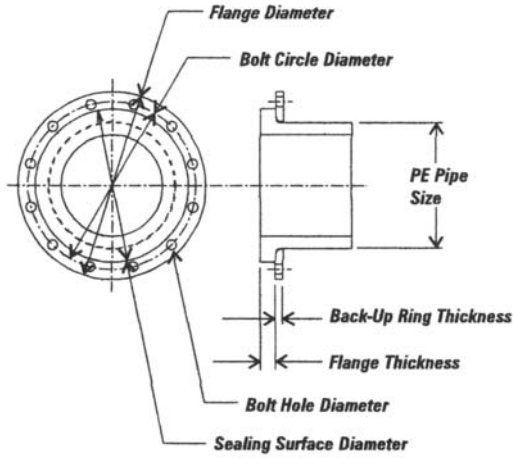


### FLANGE GASKETS

A flange gasket may not be necessary between polyethylene flanges. At lower pressures (typically 80 psi or less) the serrated flange-sealing surface may be adequate. Gaskets may be needed for higher pressures or for connections between polyethylene and non-polyethylene flanges. If used, gasket materials should be chemically and thermally compatible

with the internal fluid and the external environment, and should be of appropriate hardness, thickness, and style. Elevated temperature applications may require higher temperature capability. Gasket materials are not limited to those shown in Table 22. Other materials may also be suitable. Gasket thickness should be about 1/8"-3/16" (3-5 mm), and about 55-75 durometer Shore D hardness. Too soft or too thick gaskets may blow out under pressure. Overly hard gaskets may not seal.

**Figure 15 Flange Adapter and Back-Up Ring**



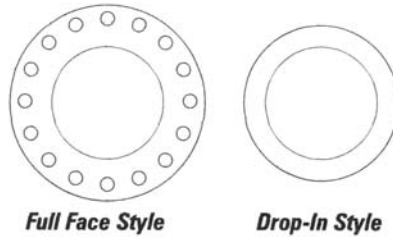
**Table 22 Materials Used for Gaskets**

Gasket Material <sup>A</sup>	Suitable Chemicals
Brown Rubber (cloth reinforced)	Water (hot or cold)
Neoprene	Oils
Red Rubber (cloth or wire reinforced)	Air, gas water, ammonia (weak solutions)
Cork Fiber	Oils (cold)

<sup>A</sup> Other materials may also be suitable for various applications.

Common gasket styles are full-face or drop-in. Full-face style gaskets are usually applied to larger sizes (12" (300 mm) and larger) because flange bolts will hold a flexible gasket in place while fitting the components together. Drop-in style gaskets are usually applied to smaller pipe sizes.

**Figure 16 Flange Gasket Styles**



### FLANGE BOLTING

Mating flanges are usually joined together with hex head bolts and hex nuts, or threaded studs and hex nuts. Bolting materials should have tensile strength equivalent to at least SAE Grade 3 for pressure pipe service, and equivalent to at least SAE Grade 2 for non-pressure service. Corrosion resistant materials should be considered for underground, underwater or other corrosive environments. Flange bolts are sized 1/8" smaller than the bolthole diameter. Flat washers should be used between the nut and the back-up ring.

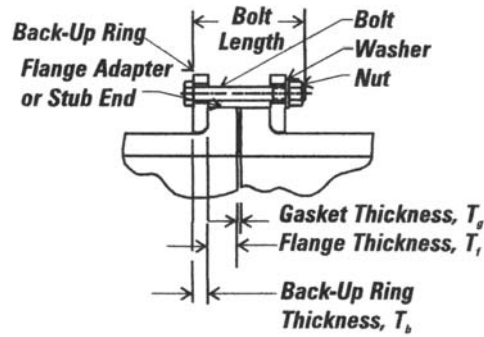
Flange bolts must span the entire width of the flange joint, and provide sufficient thread length to fully engage the nut.

$$L_B = 2(T_b + T_f) + T_g + d_B$$

Where

- $L_B$  = minimum bolt length, in
- $T_b$  = back-up ring thickness, in
- $T_f$  = flange adapter flange thickness, in
- $T_g$  = gasket thickness, in
- $d_b$  = bolt diameter, in

Figure 17 Flange Bolt Length



The  $L_B$  term provides for a standard flat washer under the nut and full thread engagement into a standard nut. Bolt length should be rounded up to the nearest standard bolt length. Rounding down may result in bolts shorter than the required minimum length. A gasket may or may not be present so gasket thickness should be included only when a gasket is used.

If threaded studs are used, then nuts and washers are installed on both sides. For two DriscoPlex™ Flange Adapters (Stub-Ends), stud length is determined by:

$$L_S = 2(T_b + T_f + d_B) + T_g$$

Where terms are as above and

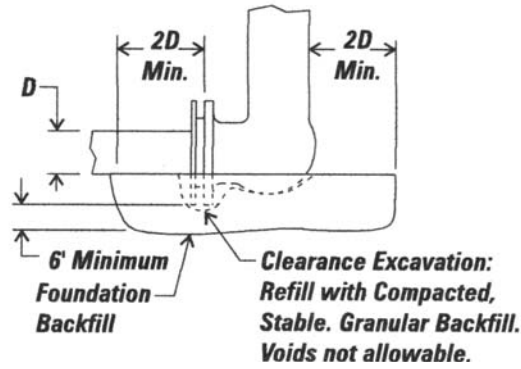
$$L_S = \text{minimum stud length, in}$$

As with bolts, stud length should be rounded up to the nearest standard length.

*Surface and above grade flanges must be properly supported to avoid bending stresses. See the Performance Pipe Engineering Manual for support design recommendations and Figures 18, 33 and 34 in this handbook.*

Below grade flange connections to heavy appurtenances such as valves or hydrants or to metal pipes require a support foundation of compacted, stable granular soil (crushed stone) or compacted cement stabilized granular backfill or reinforced concrete as illustrated in Figure 18.

**Figure 18 Buried Flange-Component Connection Foundation**



**Table 23 Flange Dimensions**

<i>IPS Pipe Size</i>	<i>Flange OD</i>	<i>Bolt Circle Diameter</i>	<i>Bolt Hole Diameter</i>	<i>No. of Bolts</i>
1-1/2	5.00	3.75	0.50	4
2	6.00	4.75	0.75	4
3	7.50	6.00	0.75	4
4	9.00	7.50	0.75	8
6	11.00	9.50	0.88	8
8	13.50	11.75	0.88	8
10	16.00	14.25	1.00	12
12	19.00	17.00	1.00	12
14	21.00	18.75	1.12	12
16	23.50	21.25	1.12	16
18	25.00	22.75	1.25	16
20	27.50	25.00	1.25	20

<i>IPS Pipe Size</i>	<i>Flange OD</i>	<i>Bolt Circle Diameter</i>	<i>Bolt Hole Diameter</i>	<i>No. of Bolts</i>
22	29.50	27.25	1.38	20
24	32.00	29.50	1.38	20
26	34.25	31.75	1.38	24
28	36.50	34.00	1.38	28
30	38.75	36.00	1.38	28
32	41.75	38.50	1.63	28
34	43.75	40.50	1.63	32
36	46.00	42.75	1.63	32
42	53.00	49.50	1.63	36
48	58.50	56.00	1.63	44
54	66.25	62.75	2.00	44

### **Flange Assembly**

**Caution – Alignment – Before tightening, mating flanges must be centered to each other and sealing surfaces must be vertically and horizontally parallel. Tightening misaligned flanges can cause leakage or flange failure.**

Before fit-up, lubricate flange bolt threads, washers, and nuts with a non-liquid lubricant grease. Gasket and flange sealing surfaces must be clean and free of significant cuts or gouges. Fit the flange components together loosely. Tighten all bolts by hand and recheck alignment. Adjust alignment if necessary.

Flange bolts are tightened uniformly in a 4-bolt index pattern to the appropriate torque value by turning the nut. A torque wrench is recommended for tightening.

**4-Bolt Index Pattern Tightening Sequence**—Use a 4-bolt index pattern as follows: 1) Select and tighten a top bolt; 2) tighten the bolt 180° opposite the first bolt; 3) tighten the bolt 90° clockwise from the second bolt; 4) tighten the bolt 180° opposite the third bolt. 5) Index the pattern one bolt clockwise and repeat the 4-bolt pattern. 6) Continue tightening in a 4-bolt index pattern until all bolts are tightened to the specified torque level. 7) Increase the tightening torque to the next level and repeat the entire 4-bolt index pattern for all flange bolts.

**Tightening Torque Values**—Establish an initial sealing surface pressure by tightening to an initial torque value of 5 ft-lbs; then increase tightening torque in increments not more than 1/4 of the final torque value. Maximum recommended bolt tightening torque values for inch-size, coarse thread bolts are presented in Table 24.

The final tightening torque value can be less than the maximum, especially with large diameter piping systems, with systems operating at low pressures and where experience shows that a sufficiently tight joint can be obtained with a lower torque value. Higher final torque values may be required for higher pressures, but recommended bolt torque values in Table 24 should not be exceeded.

*Caution – Retightening. About an hour or so after tightening to the final torque value the first time, tighten the flange bolts to the final torque level again. Polyethylene and the gasket (if used) will undergo some compression set that may loosen the bolts. Using the 4-bolt index pattern, retighten each flange bolt nut to the final torque value. As before, tighten in torque increments not more than 1/4 of the final torque value. For high pressure or environmentally sensitive or critical pipelines, a second retightening after an additional 4 hours is recommended.*

**Table 24 Flange Bolt Torque**

Bolt Size, dia – tpi	Tightening Torque, ft-lb†	
	SAE GR 2	SAE GR 3
1/2 – 13	20	30
9/16 – 12	30	45
5/8 – 11	40	60
3/4 – 10	65	100
7/8 – 9	105	150
1 – 8	150	150
1-1/8 – 8	150	150
1-1/4 – 8	150	150
1-3/8 – 8	150	150
1-1/2 – 8	150	150
1-5/8 – 8	150	150
1-3/4 – 8	150	150
1-7/8 - 8	150	150

† Where flange bolts have sufficient load capacity for a torque of 150 ft-lb or more, 150 ft-lb tightening torque is sufficient for all pipe sizes and all internal pipe pressures.

### Special Cases

#### FLANGING TO BRITTLE MATERIALS

*When flanging to brittle materials such as cast iron, accurate alignment and careful tightening are necessary. Tightening torque increments should not exceed 10 ft-lbs.* Polyethylene flange adapters and stub ends are not full-face, so tightening places a bending stress across the flange face. Over-tightening, misalignment, or uneven tightening can break brittle material flanges.

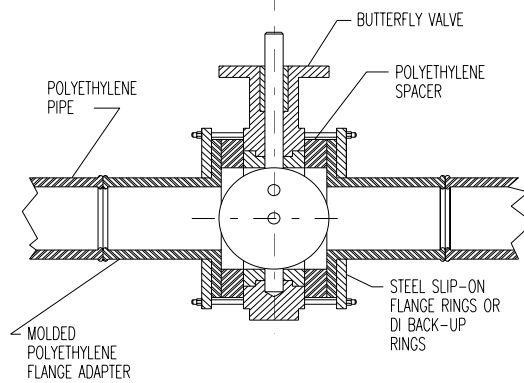
#### BUTTERFLY VALVES

When joining a polyethylene flange adapter or stub-end to a flanged butterfly valve, the inside diameter of the pipe flange should be checked for valve disk rotation clearance because the open valve disk may extend into the pipe flange. Valve operation may be restricted if the pipe

flange interferes with the disk. If disk rotation clearance is a problem, a tubular spacer may be installed between the mating flanges. Increase the length of the flange bolt or stud by the length of the spacer. Beveled (chamfered) flange adapters are available for some sizes.

Butterfly valves must be centered in the flange for proper operation. Installing a butterfly valve with the valve disk rotated open may assist with alignment. After fitting up and tightening flange bolts to the 5 ft-lbs initial torque value, operate the valve to insure that the valve disk can rotate without interference. Realign if necessary, then tighten to the final torque value using the 4-bolt index pattern.

**Figure 19 Butterfly Valve Connections**



### ***Pipe Threads***

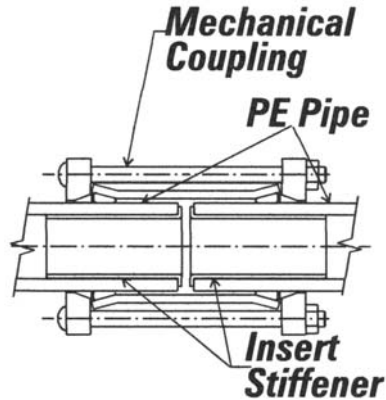
**Standard 60° v-groove taper pipe threads are not recommended for joining DriscoPlex™ OD controlled pipe or for joining components to OD controlled pipe.**

Threaded polyethylene pipe is easily stripped or cross-threaded, and the thread depth reduces wall thickness. Threaded holes in PE pipe are easily striped or cross-threaded.

### ***Pullout Resistant Mechanical Joints***

For pressure service, mechanical joints to polyethylene pipe must be resistant to pullout loads that develop in PE piping systems. Some smaller service-size joints can resist pullout until the PE pipe yields, but most provide pullout resistance that counteracts Poisson effect and thermal contraction tensile loads. Pullout resistant mechanical joints typically compress the pipe wall between an OD compression sleeve and a rigid tube or stiffener in the pipe ID. See Figure 20.

**Figure 20 Mechanical Coupling with Insert Stiffeners**



### **ID STIFFENERS FOR OD CONTROLLED PIPE**

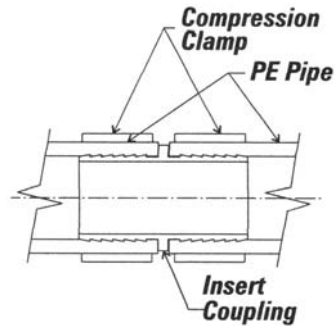
OD controlled pipe is manufactured to standards that control the OD and the wall thickness, but do not control the inside diameter. The pipe ID will vary much more than the OD or wall thickness because the ID is subject to the combined tolerances for OD and wall thickness. Depending upon the piping standard, the actual ID dimension can vary significantly. Adjustable stiffeners or stiffeners made to fit measurements taken from the actual pipe are recommended especially for larger diameters..

Insert fittings are pushed into the mating pipe bores and use individual

compression sleeves on the pipe OD's. Compression couplings fit over the pipe ends, and use individual insert stiffeners in the pipe bores that are either custom manufactured for the actual pipe ID measurement or adjustable. Adjustable stiffeners usually feature a tapered wedge or a mechanical design that allows a reduced-diameter stiffener sleeve to be expanded and locked into the actual pipe ID.

Insert fittings are commercially available for DriscoPlex™ OD controlled pipe through 2" IPS. Larger sizes may be available. Compression couplings are commercially available for DriscoPlex™ OD controlled pipe through 12" IPS. Larger sizes may be available. Sizes above 4" IPS may not be fully restrained. See Figure 20.

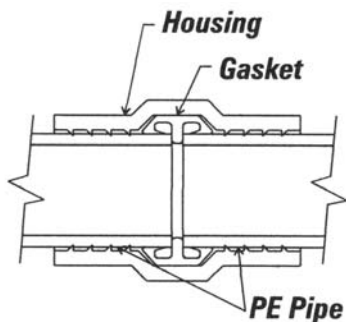
**Figure 21 Insert Coupling**



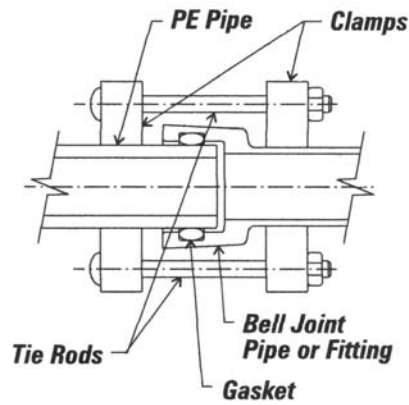
### ***Partially Restrained Joints***

A partially restrained joint is one that may withstand some longitudinal tensile load, but not completely prevent pullout. Partially restrained couplings typically are a split housing that clamps around the pipe end, but without an insert stiffener in the pipe bore. The housing clamp surface will usually have sharp edged grooves or teeth to grip the pipe OD. A gasket provides a leak seal between the pipe ends. See Figure 22.

**Figure 22 Partially Restrained Compression Coupling**



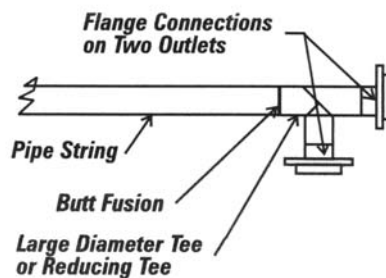
**When joining plain end polyethylene pipe to bell-and-spigot or mechanical-joint type fittings or pipe in a pressure piping system, an internal stiffener must be installed in the polyethylene pipe end, and an external joint restraint (such as clamps and tie rods) must be used to restrain against pullout loads.** Typically, external joint restraints use external clamps behind the bell and around the PE pipe end, and tie rods between the clamps. See Figure 23. The stiffener in the PE pipe end extends under the external clamp.

**Figure 23 External Joint Restraint**

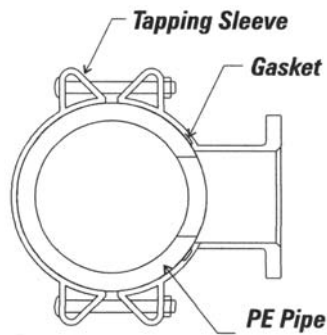
### **Branch Connections**

Branch connections may be made with equal outlet and reduced outlet tees, wyes and crosses that are installed in the line during construction. During or after laying the main, service saddles, tapping tees and branch saddles may be saddle fused or mechanically connected to the main. Field saddle fusion fittings are usually limited to 4" IPS and smaller branch connections on 12" IPS and smaller mains. **Mechanical saddle or branch fittings that clamp around the main and seal with gaskets, should be limited to applications where service temperatures are relatively constant and stable.** Consult the fitting manufacturer for usage recommendations and limitations.

When 16" IPS or larger fabricated equal outlet or reduced outlet tees are installed in the main during construction, two of the three field connections to the tee should be flanged. See Figure 24. The tee is usually butt fused to the end of a pipe run, then set into location. The mating run and branch pipes are then connected to the fitting flanges. *When a 16" IPS or larger fabricated fitting is joined to more than one pipe, field handling can break the fitting.*

**Figure 24 Large Diameter Tee Installations**

After a system has been installed, large diameter branch taps may be made with commercially available tapping sleeves for IPS outside diameter pipe. See Figure 25. Tapping sleeves must be installed in accordance with manufacturer's instructions. Hole saws must be sized in accordance with the tapping sleeve manufacturer's instructions and should be designed for cutting polyethylene pipe. Smaller service connections can be made by saddle fusing a Service Saddle or Tapping Tee to the main. Commercially available strap-on service saddles may be used. *Mechanical strap-on Service Saddles must secure over a wide bearing area such as wide straps over a curved plate or double band straps. U-bolt type service saddles are not recommended.* Full encirclement band style service saddles may also be used. Service saddles may also be used for connections to gauges, vacuum breakers, and air release valves.

**Figure 25 Tapping Sleeve**

### **Repair Sleeves**

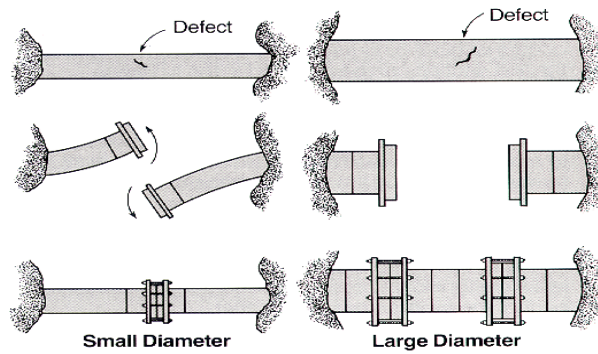
A repair sleeve is a wrap-around sheet metal sleeve with a bolted seam. An elastomeric gasket is used between the sleeve and the pipe. Repair sleeves are used to restore leak-tightness where a pipe has been holed, but repair sleeves do not provide thrust restraint and should not be used to join pressure pipe.

A repair sleeve should never be used to repair a leak at a fusion joint. Correctly made fusion joints do not leak. A leak at a fusion joint indicates a faulty fusion that must be cut out and redone.

***WARNING: A leak at a fusion joint indicates a faulty joint that could separate completely without warning at any time, and cause injury or damage. Do not approach a leaking fusion joint. Depressurize the line before making repairs.***

### **Repair Connections**

Installed systems may be repaired. Repairs typically involve replacing a pipe section. In some cases, pipe ends may be deflected laterally and electrofusion, mechanical compression couplings with insert stiffeners or flanges may be used. In other cases, a flanged spool may be installed. See Figure 26.

**Figure 26 Repair Connections**

## UNDERGROUND INSTALLATION

**WARNING: To prevent injury to persons and property damage, safe handling and construction practices must be observed at all times. The installer must observe all applicable local, state, and federal safety codes and any safety requirements specified by the owner or the project engineer.**

Buried installations generally involve trench excavation, placing pipe in the trench, placing embedment backfill around the pipe, then placing backfill to the required finished grade. Pipe application, service requirements and size, soil conditions, backfill soil quality, burial depth and joining requirements will all affect the installation.

The care taken by the installer during installation will dramatically affect system performance. A high quality installation in accordance with recommendations and engineered plans and specifications can ensure performance as designed, while a low quality installation can cause substandard performance.

At a minimum, non-pressure and gravity flow DriscoPlex™ polyethylene piping systems should be installed in accordance with ASTM D 2321, *Standard Practice for Underground Installation of Thermoplastic Pipe for Sewers and Other Gravity Flow Applications*, and pressure systems should be installed in accordance with ASTM D 2774, *Standard Practice*

for *Underground Installation of Thermoplastic Pressure Piping*. System plans and specifications may include additional requirements. The installer should be familiar with this information before installing Performance Pipe DriscoPlex™ piping products.

### **Pipe Embedment Terminology**

The backfill materials surrounding a buried pipe are explained below. See Figure 27.

**Foundation** – A foundation is required only when the native trench bottom does not provide a firm working platform, or the necessary uniform and stable support for the installed pipe. If a foundation is installed, bedding is required above the foundation.

**Initial Backfill** – This is the critical zone of embedment surrounding the pipe from the foundation to at least 6" over the pipe. The pipe's ability to support loads and resist deflection is determined by the quality of the embedment material and the quality of its placement. Within this zone are bedding, haunching, primary and secondary zones.

**Bedding** – In addition to bringing the trench bottom to required pipe bottom grade, the bedding levels out any irregularities, and ensures uniform support along the pipe length. Bedding is required when a foundation is installed, but a foundation may not be required to install bedding.

**Haunching** – The embedment under the pipe haunches supports the pipe and distributes the load. The quality of the haunching backfill and its placement are the most important factors in limiting flexible pipe deformation.

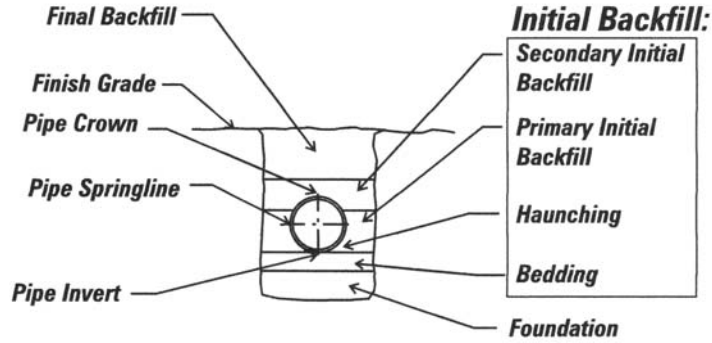
**Primary Initial Backfill** - This embedment zone provides primary support against lateral pipe deformation. It extends from pipe bottom grade to at least 3/4 of the pipe diameter height, or to at least 6" over the pipe crown if the pipe is installed where the pipe will be continuously below normal groundwater levels.

**Secondary Initial Backfill** - Embedment material in this zone distributes overhead loads, and isolates the pipe from any adverse effects from placing final backfill material. Where the ground water level may rise over the pipe, the secondary initial backfill should be a continuation of the primary initial backfill.

**Final Backfill** – Final backfill is not an embedment material, however, it

should be free of large rocks, frozen clods, lumps, construction debris, stones, stumps, and any other material with a dimension greater than 8".

**Figure 27 Embedment Terminologies**



### **Trenching**

In stable ground, minimum trench width,  $B_d$ , will vary by the pipe diameter as illustrated in Figure 28 and Table 25. The trench must be wide enough to place and compact backfill soils in the haunch areas below the pipe springline. To minimize the load on the pipe, the maximum trench width should not exceed the minimum trench width by more than 18" plus the thickness of any sheeting, shoring or shielding, unless approved by the engineer. For trenches containing multiple pipes, the distance between parallel pipes should be the same as the clearance distance between the pipe and the trench wall. See Table 25.

Figure 28 Trench Width

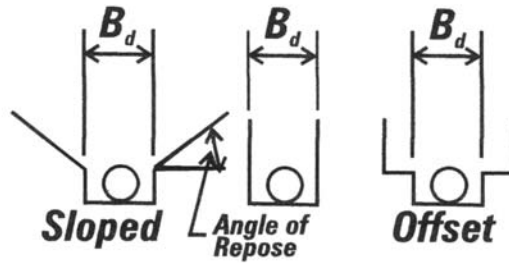
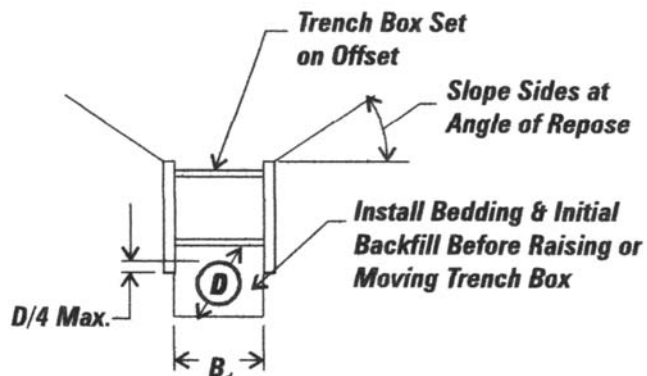


Table 25 Minimum Trench Widths

Nominal Pipe OD, in	Minimum Trench Width, $B_d$ , in	Parallel Pipe Clearance, in
<3	12	4
3 – 16	Pipe OD + 12	6
18 – 34	Pipe OD + 18	9
36 – 63	Pipe OD + 24	12
72 - 96	Pipe OD + 36	18

Depending upon trench soil stability and depth, trench sides above the pipe crown may need to be sloped or stepped as illustrated in Figure 28. When trenching in ground not considered to be stable, the trench width above the pipe crown should be sloped and/or widened. Trench sidewall bracing such as trench shield or sheeting should always be used wherever required by site safety conditions, by OSHA, or by other regulatory agencies. When using a trench box, a trench offset should be excavated at a depth between the pipe crown and 1/4 pipe diameter below the pipe crown; then the trench box should be installed on the offset shelf. See Figure 29. Further excavation of the pipe zone trench down to the foundation grade should be performed within the protection of the trench box.

**Figure 29 Trench Box Installations**

For pressure piping systems such as water mains, gas mains, or sewage force mains, the grade of the trench bottom is not critical. The trench bottom may undulate, but must support the pipe continuously and be free from ridges, hollows, lumps and the like. Any significant irregularities must be leveled off and/or filled with compacted embedment backfill. If the trench bottom is reasonably uniform, and the soil is stable and free of rock, foundation or bedding may not be required.

For gravity drainage systems the trench bottom determines the pipe grade, so the trench bottom must be constructed to the required grade, usually by installing foundation and bedding, or bedding. If the trench bottom is reasonably uniform and the soil is stable and free of rock, foundation or bedding may not be required.

The pipe should be laid on a stable foundation. Where water is present in the trench, or where the trench bottom is unstable, excess water should be removed before laying the pipe. Ground water should be lowered to below the level of the bedding material. During dewatering, take care not to remove sand or silt, and not to displace foundation or bedding soil material.

Where an unstable trench bottom exists such as in mucky or sandy soils with poor bearing strength, trench bottom stabilization is required by excavating the trench below the pipe bottom grade, and installing a

foundation and bedding, or a bedding of compacted Class I or Class II materials to the pipe bottom grade. When required, the minimum foundation thickness is 6". When bedding and foundation are both required, the minimum bedding thickness is 4". Without a foundation, the minimum bedding thickness is 6". All materials used for bedding, haunching, primary and secondary backfill should be installed to at least 90% Standard Proctor Density, or as specified by the engineer.

Mechanical compaction, which may be as simple as shovel slicing Class I material, is usually required to achieve 90% Standard Proctor Density.

When the pipe is laid in a rock cut or stony soil, the trench should be excavated at least 6" below pipe bottom grade, and brought back to grade with compacted bedding. Remove ledge rock, boulders, and large stones to avoid point contacts, and to provide a uniform bed for the pipe.

### ***Placing Pipe in the Trench***

OD controlled pipe up to about 8" diameter and weighing roughly 6 lbs per foot or less can usually be placed in the trench manually. Heavier, larger diameter OD controlled pipe will require appropriate handling equipment to lift, move, and lower the pipe into the trench. **Pipe must not be dumped, dropped, pushed, or rolled into the trench.**

**Appropriate safety precautions must be observed whenever persons are in or near the trench.** Requirements for handling and lifting equipment are discussed earlier in this handbook.

### ***Cold (Field) Bending***

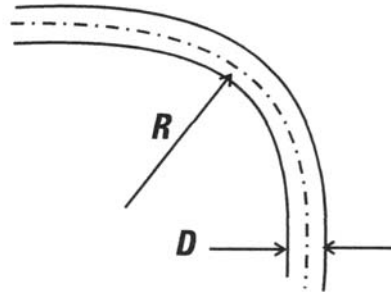
Coiled lengths and long strings of OD controlled pipe may be cold bent in the field. Allowable bend radius is determined by the pipe diameter and dimension ratio. See Table 26. Because fittings and flange connections are rigid compared to pipe, the minimum field-bending radius is 100 times the pipe OD when a fitting or a flange connection is present in the bend.

Temporary blocks or restraints must be removed before installing final backfill, and any voids must be filled with compacted initial backfill material.

**Considerable force may be required to field bend the pipe, and the pipe may spring back forcibly if the restraints slip or are**

**inadvertently released while bending. Observe appropriate safety precautions during field bending.**

**Figure 30 Bend Radius**



**Table 26 Minimum Cold (Field) Bending Radius (Long-Term)**

<i>Pipe DR</i>	<i>Minimum Cold Bending Radius</i>
≤ 9	20 times pipe OD
> 9 – 13.5	25 times pipe OD
> 13.5 – 21	27 times pipe OD
> 21	30 times pipe OD
Fitting or flange present in bend	100 times pipe OD

### ***Installing Fabricated Fittings***

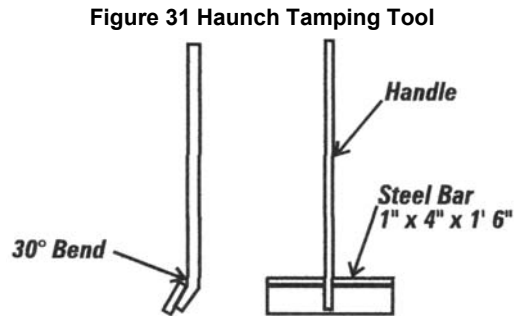
***To avoid field damage, large diameter (16" IPS and above), do not join fabricated directional fittings such as elbows, tees, wyes, and crosses to more than one pipe before placement in the trench.*** The remaining outlet connections are made with flanges or mechanical couplings after placement in the trench. Connecting pipes to more than one outlet, then attempting to lift, move, and lower the assembly into the trench frequently results in fitting breakage and is not recommended. See Figure 24.

### ***Pipe Embedment Soils***

Preferred embedment materials for Performance Pipe OD controlled pipe are Class I and Class II angular gravels and sands classified as meeting soil types GW, GP, SW or SP and dual classifications beginning with one of these symbols as defined in ASTM D 2487. These materials should be used for bedding, haunching, and for primary and secondary initial backfill. The maximum particle size should be limited to 1/2" for pipes to 4" diameter, 3/4" for pipes 6" to 8" diameter, 1" for pipes 10" to 16" diameter and 1-1/2" for larger pipes.

### ***Embedment Backfilling***

The haunch areas should be completely filled and void free to the extent possible. For the lower half of the haunch area, materials should be shoveled evenly into the area on both sides of the pipe in layers not more than 4" thick, and compacted with an angled haunch-tamping tool like that illustrated in Figure 31. Layers can then be increased to 6" and flat-tamping tools can be used.



Following haunching, primary and secondary initial backfill materials should be placed in 6" layers and compacted with flat tamping tools. If mechanical tampers are used, take care not to damage the pipe. If sheeting has been used, the sheeting should be lifted progressively for each layer.

### **Joint Restraining with Thrust Blocks**

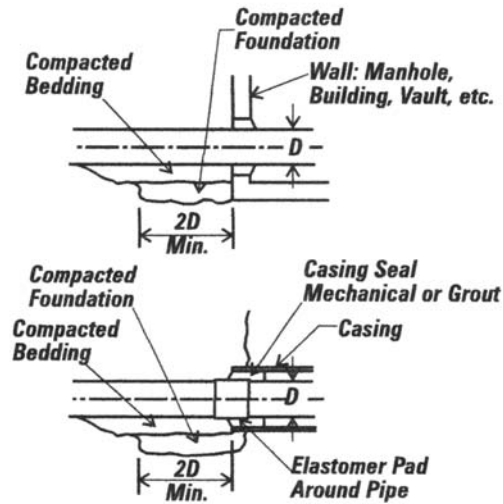
DriscoPlex™ polyethylene pressure pipe systems must be assembled with fully restrained joints, or with partially restrained joints AND external joint restraints. Such systems are fully restrained, and do not require thrust block restraints.

### **Controlling Shear and Bending Loads**

DriscoPlex™ pipes that enter or exit a casing or a structure wall such as a building wall, vault, or manhole, must be protected against shear and bending loads that can develop from settlement and embedment consolidation.

A compacted foundation and compacted bedding should be installed below the pipe where it exits the casing or structure as illustrated in Figure 32. At a casing entry or exit, the pipe should be wrapped with an elastomeric sheet material; then the annulus between the pipe and the casing should be sealed either mechanically or with a cement grout. The seal prevents backfill migration into the annulus.

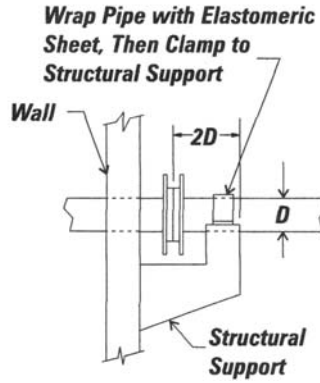
**Figure 32 Controlling Shear and Bending Loads**

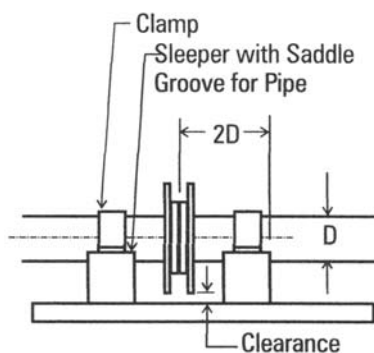


Where OD controlled pipe is flanged at a wall such as a building or vault wall, a structural support as illustrated in Figure 33 is recommended to prevent shear and bending loads. Within the clamp, the pipe is protected against chafing by wrapping it with an elastomeric sheet.

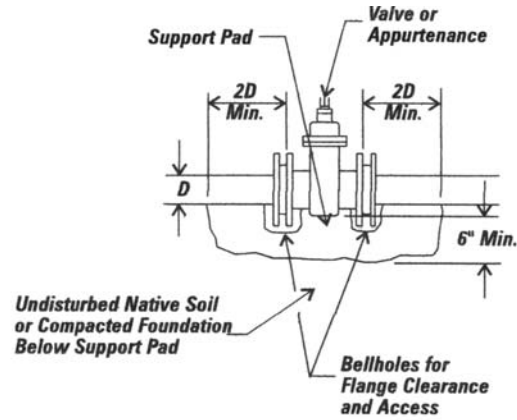
Where DriscoPlex™ pipe or fittings are joined to valves, hydrants, other heavy devices, or rigid pipes, a support pad as illustrated in Figure 35 should be provided below the device or rigid pipe, and for at least two pipe diameters length under the connecting pipes. Support pad materials should be at least compacted Class I or II soil, or cement stabilized Class I, II, or III soils, or poured concrete. Embedment soils around the connecting pipes, the device, and in any bell holes must be compacted.

**Figure 33 Flange Support at Wall**



**Figure 34 Protecting Connections to Flanges and Fittings**

Where pipe is connected to rigid devices such as fabricated directional fittings or where flanges or other rigid connections are employed, the pipe must be protected from shear, flexing and bending. Flanges laid on the surface can become anchored in the soil, and should be supported on sleepers. Figures 34 and 42 illustrate a method for protecting connections to directional fittings and flanged connections to other appurtenances. Wrap elastomeric or rubber sheet material around the pipe under the clamps.

**Figure 35 Appurtenance Support Pad**

### ***Final Backfilling***

In general, final backfill may be material excavated from the trench provided it is free of unsuitable matter such as lumps, stones, frozen clods, construction debris, boulders, and other materials exceeding 8" in their longest dimension.

Where the trench is subject to surcharge loads such as H-20 or E-80 live loads, or building foundations or footings, or paved parking or storage areas, final backfill should be an angular Class I or Class II granular material, compacted to at least 95% Standard Proctor density or as specified by the engineer.

### ***Poisson Effects***

When non-PE pipe and components are installed in the same pressure pipeline with PE pipe, or when PE pipe is connected to unrestrained joint piping such as bell and spigot joint PVC or ductile iron, unrestrained joints in the transition area should be protected against pullout disjoining.

When pipes made from ductile materials are pressurized, the diameter expands slightly and the length decreases in accordance with the

Poisson ratio of the material. With unrestrained bell and spigot joined lengths, the effect is limited to the individual pipe lengths, but with fully restrained pipes such as fusion-joined PE pipe, the effect is cumulative over the entire restrained length of pipe. When fusion-joined polyethylene pipe is connected to unrestrained mechanical couplings or bell and spigot joint PVC or ductile iron piping, Poisson effect pipe shortening can cause pullout disjoining of unrestrained joints where the PE pipe transitions to the unrestrained non-PE pipe. To prevent Poisson effect pullout disjoining in the transition area, provide protection by installing external joint restraints at unrestrained bell and spigot joints, or by installing an in-line anchor in the HDPE pipeline, or by a combination of both techniques.

Conventional thrust blocks at directional fittings are not effective against Poisson effect pullout because conventional thrust blocks are intended to resist thrust forces that would push the fitting off the end of the pipe, where Poisson effect forces pull the pipe out of the joint, a force that thrust blocks cannot counteract. As well, snaking pipe in the trench is generally not effective.

### ***The Poisson Effect***

When a tensile stress is applied to a material, the material elongates in the direction of the applied stress, and draws in at right angles to the direction of the applied stress. This relationship, called the Poisson effect, is a natural response to applied stress that occurs with all materials, but is particularly apparent with ductile materials. For example, when a metal bar is pulled in a tensile test, it stretches out and necks down on the sides. Likewise, a rubber band elongates and necks down on the sides when it is pulled. When pipes such as polyethylene, PVC and metal pipes are pressurized, the diameter will expand slightly, and due to the Poisson effect, the pipe will shorten in length.

A pipe section with fully restrained joints such as a long string of butt-fused HDPE pipe will transmit Poisson effect pipe shortening from length to length through the restrained joints along the pipe string. Restrained joints include fusions, bolted flange connections, MJ adapter connections or other restrained mechanical connections. If an unrestrained bell and spigot or mechanical sleeve joint is in-line with the restrained section, the cumulative Poisson effect shortening may cause in-line unrestrained joints or connections to be pulled apart. Therefore,

unrestrained joints or mechanical connections that are in-line with fully restrained HDPE pipe must be either restrained or otherwise protected against pullout disjoining.

## **Connection Restraint Techniques**

### **ADAPTERS FOR FLANGES AND MECHANICAL JOINTS**

Adapters are available for connecting DriscoPlex™ HDPE pipe to flanges and to Mechanical Joints. DriscoPlex™ Flange Adapters and MJ Adapters are fully pressure rated and fully restrained. Flange Adapters and MJ Adapters are butt fused to the HDPE pipe, then connected to the mating flange or mechanical joint. See Performance Pipe fittings literature and technical notes for information and installation instructions.

### **PLAIN-END HDPE PIPE CONNECTIONS**

When a plain-end HDPE pipe is inserted into a PVC or ductile iron bell or into a mechanical joint bell or component, a stiffener inside the HDPE pipe end and an external mechanical joint restraint are required. The internal stiffener must extend into the HDPE pipe end so that the stiffener supports the HDPE pipe under the seal and under the joint restraint clamp. The external restraint provides pullout resistance.

*An ID stiffener and external mechanical restraint are required when plain end HDPE pressure pipe is connected to:*

- Bell and spigot (push-on) joint in PVC pipe and ductile iron fittings, valves, hydrants and pipe;
- Bolted sleeve couplings;
- Mechanical joint pipe, fittings, valves and hydrants (when a DriscoPlex™ MJ adapter is not used).

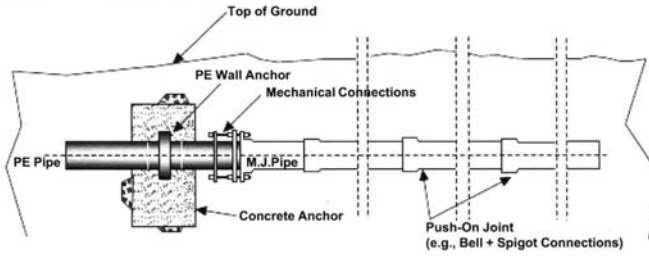
For PE butt fusion and where DriscoPlex™ Flange Adapter and DriscoPlex™ MJ Adapter fittings are used, ID stiffeners and external joint restraints are *NOT* required.

## **Pullout Prevention Techniques**

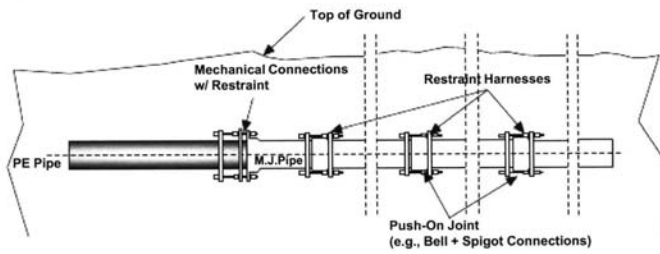
### ***The transition region where a long HDPE pipe string is connected***

*in-line to unrestrained piping can extend several joints into the non-PE pipe system because a restrained connection at the transition joint can transmit Poisson shortening to the next in line unrestrained joint in the non-PE pipe. Typical pullout prevention techniques include restraining several non-PE pipe joints down line from the transition connection, or restraining the transition connection and installing an in-line anchor in the HDPE pipe close to the transition connection. Figures 36 and 37 illustrate typical pullout prevention techniques.*

**Figure 36 Pullout Prevention Technique**



**Figure 37 Pullout Prevention Technique**



### **Pullout Force**

Poisson effect pipe shortening will occur whenever the pipe is pressurized. Because internal pipe pressures are higher during pressure testing and surge events, Poisson effect pipe shortening can be greater at these times compared to normal steady pressure operation.

*Caution – Before pressure testing, all mechanical joint restraints must be completely installed and secured per manufacturer's instructions, and concrete at in-line anchors and thrust blocking (if used) must be sufficiently cured and properly backfilled. See Performance Pipe Technical Note PP-802-TN Leak Testing.*

**The Project Design Engineer should determine the Poisson Effect pullout force conditions that are appropriate for his application; then determine the appropriate techniques to protect unrestrained in-line mechanical connections against disjoining from Poisson effect pullout forces.**

For a given PE pipe diameter and DR, approximate Poisson effect pullout force may be determined by multiplying the end area of the PE pipe by the product of the internal pressure hoop stress and the appropriate Poisson ratio.

$$F = S \mu \pi D_M^2 \left[ \frac{1}{DR} - \frac{1}{DR^2} \right]$$

Where F = pullout force, lbs  
S = internal pressure hoop stress, lb/in<sup>2</sup>

$$S = \frac{P(DR - 1)}{2}$$

P = internal pressure, lb/in<sup>2</sup>  
DR = dimension ratio  
 $\mu$  = Poisson ratio (for PE, 0.45 for long-term stress; 0.35 for short-term stress)  
 $\pi$  = Pi (approximately 3.142)  
D<sub>M</sub> = pipe mean diameter, in

Table 27 presents approximate Poisson effect pullout forces for selected

sizes of PE pipe while operating at rated system internal pressure, during leak testing at 150% of rated system pressure and during a severe water hammer event while operating at steady pressure that causes a pressure surge to 200% of rated system pressure.

**Table 27 Approximate Poisson Effect Pullout Force**

<i>DIPS Pipe Size (DR 11)</i>	<i>Approximate Pullout Force, lbs (a)</i>		
	<i>Operating at Full Rated Pressure (b)</i>	<i>During Pressure Tests at 150% of Rated Pressure (c)</i>	<i>Operating at Full Rated Pressure Plus Maximum Allowable Occasional Surge Pressure (d)</i>
4"	1,892	2,208	3,364
6"	4,102	4,786	7,293
8"	6,953	8,112	12,361
10"	10,801	12,602	19,202
12"	15,195	17,727	27,013
16"	23,928	27,916	42,539

(a) Values for water at 73°F.  
 (b) Rated pressure for DR 11, Class 160 = 160 psi. Pullback force determined using long-term Poisson ratio of 0.45.  
 (c) Pullback force determined using short-term Poisson ratio of 0.35.  
 (d) Total pressure in pipe during surge event = 160 psi steady pressure + 160 psi surge pressure = 320 psi. Values determined by combining pullback force for steady pressure (long-term Poisson ratio of 0.45) plus pullout force for surge event (short-term Poisson ratio of 0.35).

Other longitudinal forces from thermal expansion and contraction, fluid thrust, or installation are not incorporated into table values. See the Performance Pipe Engineering Manual for information on additional loads.

### ***Special Underground Installation Techniques***

Because of its flexibility and the high integrity of properly made butt fusion joints, special installation techniques may be employed to install DriscoPlex™ OD controlled pipe. Special techniques include plowing, planting or pulling pipe into a narrow trench, horizontal boring, and directional boring. These techniques minimize excavation by making a tight fitting trench cut or hole for the pipe, and either pulling or placing the pipe in the cut. They require suitable native soil conditions that are free of large rocks, and except directional boring, are generally limited to

shallower depths.

### PLOWING AND PLANTING

Plowing and planting involve cutting a narrow trench, and feeding the pipe into the trench through a shoe or chute fitted just behind the trench cutting equipment. Trench cuts for pipes around 1-1/2" IPS and smaller are frequently made with vibratory plows. Larger sizes use wheel or chain type trenchers with semi-circular cutters. The trench width should be only slightly larger than the pipe outside diameter.

The shoe or chute should feed the pipe into the bottom of the cut. The short-term pipe bending radius through the shoe may be tighter than the long-term cold bending radius (Table 26), but it must not be so tight that the pipe kinks. Table 28 presents minimum short-term bending radii for applications such as plowing and planting. The pipe's path through the shoe or chute should be as friction free as practicable.

**Table 28 Minimum Short-Term Bending Radius**

<i>Pipe Dimension Ratio</i>	<i>Minimum short-Term Bending Radius</i>
≤ 9	10 times pipe OD
> 9 – 13.5	13 times pipe OD
> 13.5 – 21	17 times pipe OD
> 21	20 times pipe OD

Pipe is usually fed over the trenching equipment and through the shoe or chute from coils or straight lengths that have been butt fused into a long string. Pipe up to 12" IPS has been installed using this method.

### PULLING-IN

Pulling-in involves cutting a trench, then pulling the pipe in from one end of the trench. Pulling-in may be accomplished as a simultaneous operation by attaching the leading end of the pipe behind the trench cutter, or as a separate operation after the trench has been opened. In either case, pulling-in requires a relatively straight trench and the pulling force applied to the pipe must not exceed the Allowable Tensile Load, ATL, (safe pull strength) for the pipe. Therefore, this method is limited to shorter runs.

Allowable Tensile Load (safe pull strength) may be determined by:

$$ATL = \pi D^2 f_Y f_T T_Y \left( \frac{1}{DR} - \frac{1}{DR^2} \right)$$

Where

- ATL = allowable tensile load, lb
- D = pipe outside diameter, in
- $f_Y$  = tensile yield design (safety) factor, Table 29
- $f_T$  = time under tension design (safety) factor, Table 29
- $T_Y$  = pipe tensile yield strength, lb/in<sup>2</sup> (Table 30)
- DR = pipe dimension ratio (DR or SDR)

When polyethylene pipe is subjected to a significant short term pulling stress, the pipe will stretch somewhat before yielding. However, if the pulling stress is limited to about 40% of the yield strength, the pipe will usually recover undamaged to its original length in a day or less after the stress is removed.

**Table 29 Recommended Design Factors for ATL**

<i>Factor</i>	<i>Parameter</i>	<i>Recommended Value</i>		
$f_Y$	Tensile yield design factor†	0.40		
$f_T$	Time under tension design factor	1.0 for up to 1 h	0.95 for up to 12 h	0.91 for up to 24 h
† Design and safety factors are the inverse of each other. Multiplying by a 0.40 design factor is the same as dividing by a 2.5 safety factor.				

Pipe yield strengths may be estimated by using the values from Table 30. Unlike more brittle materials, polyethylene pipe materials can stretch over 400% between tensile yield and tensile break. Further, tensile yield strength and tensile break strength are about the same value, so pulling load gauges will not show that a pipe has yielded because the pipe will stretch to the breaking point with little change in pulling force. The only indication will be that the trailing end stops while the pulling end continues to move.

**Table 30 Approximate Tensile Yield Strength Values**

Material	Approximate Tensile Yield Strength, $T_y$ , at Pipe Temperature			
	73°F (23°C)	100°F (38°C)	120°F (49°C)	140°F (60°C)
HDPE	3200 lb/in <sup>2</sup> (22.1 MPa)	2910 lb/in <sup>2</sup> (17.4 MPa)	2365 lb/in <sup>2</sup> (13.7 MPa)	2015 lb/in <sup>2</sup> (14.3 MPa)
Temperature Factor	1.00	0.91	0.74	0.63

When pulling-in polyethylene pipe, especially smaller diameters, the pulling force should be monitored and kept below the ATL value for the pipe size, and both the pulling end and trailing end should be monitored for continuous, smooth movement. **When pulling equipment can exceed the ATL value of the pipe, install a weak-link device at the lead end of the polyethylene pipe.** The weak-link device should be set to disengage at the ATL value or lower.

Because pull-in loads will cause the pipe to stretch, the leading end should be pulled past the termination point by 3-5% of the total pulled-in length, and the trailing end should be left long by the same amount. Final tie-ins should be made a day after the pull to allow the pipe to recover from the pulling stress and contract to its original pre-pull length. The extra length at both ends assures that the pipe won't recede back past the tie-in points as it recovers from the pull.

**Table 31 Approximate ATL Values<sup>A</sup>**

IPS Size	ATL <sup>A</sup> , lb			
	SDR 17	SDR 13.5	SDR 11	SDR 9
1/2"			235	280
3/4"			378	451
1"			575	687
1-1/4"			916	1,095
1-1/2"			1,200	1,434
2"			1,875	2,241
3"	2,728	3,380	4,072	4,867
4"	4,510	5,587	6,732	8,045
6"	9,774	12,109	14,591	17,437
8"	16,566	20,523	24,730	29,553
10"	25,735	31,882	38,416	45,910

IPS Size	ATL <sup>A</sup> , lb			
	SDR 17	SDR 13.5	SDR 11	SDR 9
12"	36,202	44,849	54,041	64,582
14"	43,648	54,073	65,156	77,866
16"	57,010	70,627	85,102	101,702
18"	72,153	89,387	107,707	128,717
20"	89,077	110,354	132,972	158,910
22"	107,784	133,528	160,896	192,281
24"	128,271	158,910	191,480	225,530

<sup>A</sup> ATL values in table are at 73°F and for 1 hour or less pull duration using 3200 psi tensile yield strength. Depending on the application, adjust the ATL value for temperature or pull duration or both. For elevated temperature, multiply ATL value by temperature factor from Table 30; for pull duration between 1 and 12 hours, multiply ATL value by 0.95; and for pull duration between 12 and 24 hours, multiply ATL value by 0.91.

### HORIZONTAL BORING

Horizontal boring or road boring is usually performed to install a casing below existing roadways or structures where opening a trench may be impractical or undesirable. Polyethylene pipe is then installed in the casing. Typically, entry and exit pit excavations are required. Horizontal bores are usually performed using a rotating auger within a steel casing. The auger projects just ahead of the casing, and the auger and casing are advanced together across to the exit pit. Typically, either the auger casing is left in place or a new casing is installed by pulling it in from the exit pit while withdrawing the bore casing.

When installed in a casing, OD controlled polyethylene pipe does not require centering spacers (centralizers) for electrical isolation to a metal casing. Polyethylene is non-conductive and will not affect casing cathodic protection. Allowing the pipe to snake inside the casing can usually accommodate minor thermal length changes of the polyethylene pipe in the casing. If used, centering spacers will force thermal expansion thrust loads to the pipe ends, which may weaken or break casing end seals.

Unless groundwater pressure could cause pipe collapse (see Table 14), grouting the casing annulus is not required. The PE pipe must be protected against shear and bending loads at the casing entry and exit.

When pulling PE pipes into the casing, the Allowable Tensile Load (ATL) for the pipe must not be exceeded.

### **HORIZONTAL DIRECTIONAL DRILLING (HDD)**

Horizontal directional drilling uses directional drilling techniques to guide a drill string along a borepath around obstacles such as under rivers or lakes or through congested underground infrastructure. As with horizontal boring, horizontal directional drilling may be used to install a casing, or to directly install long strings of DriscoPlex™ OD controlled pipe.

As the hole is bored, a steel drill string is extended behind a cutting head. Drilling mud is used to cool the cutter, flush excavated soil from the borehole and lubricate the borehole. At the end of the borepath, the drill string is angled upwards and through the surface. The cutting head is removed and a backreamer attached. The pipe string is attached to the backreamer. When the pullback force exceeds the ATL for the PE pipe, a weak-link or breakaway device is installed between the backreamer and the PE pipe. As the drill string is withdrawn to the drilling rig, the backreamer enlarges the borehole and the pipe string is drawn in. To prevent damage to the PE pipe during pullback, the movement of the pipe string and the pulling load on the polyethylene pipe must be monitored, and the pulling load on the pipe string must not exceed the ATL value for the pipe. Information on horizontal directional drilling is available in ASTM F 1962 and Performance Pipe Technical Note PP 800-TN.

### ***Sliplining***

In sliplining or insertion renewal rehabilitation, a smaller diameter DriscoPlex™ slipliner pipe is installed in the ID of an existing host pipe. Table 9 provides comparative flows for clay and concrete pipes rehabilitated by sliplining with DriscoPlex™ piping.

Sliplining installations may be subject to thermal length changes. Thin wall sewer liners may collapse if external hydrostatic load due to high water table or flood conditions is too high. Resistance to collapse from external hydrostatic load may determine the minimum wall thickness for the slipliner. See Table 14.

Figure 38 illustrates sanitary sewer sliplining. Before sliplining, the

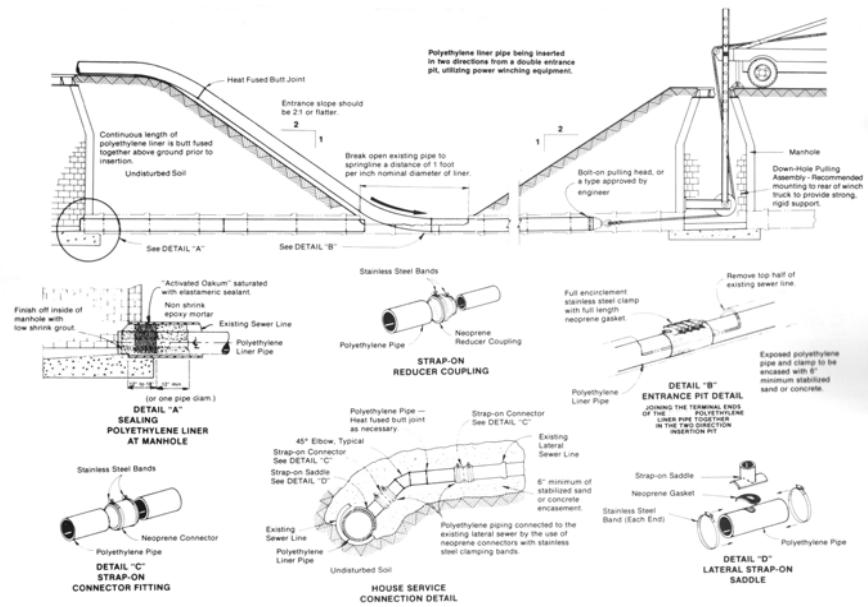
sewer must be cleaned and cleared of roots and debris. Video inspection is also used to locate service connections, offsets and structural deterioration. In general, service connections; the pulling pit, badly deteriorated areas, significant offsets and bends tighter than 11-1/4° will require excavation. Manhole locations are commonly used as pulling pit locations. For more information, see ASTM F 585 *Standard Practice for Insertion of Flexible Polyethylene Pipe Into Existing Sewers* and the *Performance Pipe Engineering Manual*.

Sliplining with DriscoPlex™ OD controlled pipe may be used for pressure or non-pressure service and may be installed by pulling or pushing or a combination of both. For pulling-in, the usual diametrical clearance between the original pipe inside diameter and the renewal pipe outside diameter should be 10% or more of the original pipe ID. For push-in sliplining, the diametrical clearance should be between 10% and 30%. When pulling-in, the tensile load on the liner must not exceed the ATL for the pipe.

DriscoPlex™ OD controlled slipliners may also be pushed in using a fabric choker sling around the liner, hooked to a backhoe bucket as illustrated in Figure 40.

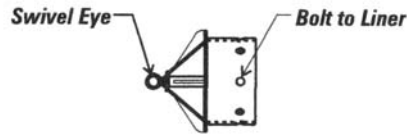
After liner installation, service connections are reestablished. Point excavations are usually required. Any branch connection appropriate for the service may be used. For a mechanical branch connection such as a strap-on saddle or an Inserta-Tee® (Figure 41), the casing crown down to the springline must be removed to expose the top of the liner. For saddle fusion or to install an electrofusion saddle to the liner, the entire casing must be removed for complete access to the liner. The point excavation and casing removal must provide clearance for equipment and personnel.

**Figure 38 Sliplining Sewer Rehabilitation with DriscoPlex™ Polyethylene Pipe**

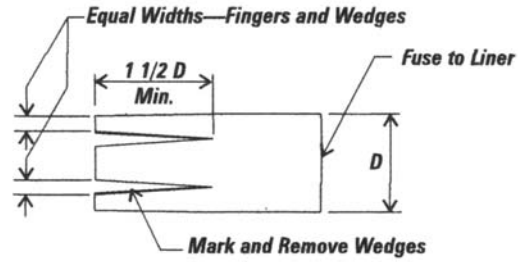


**Figure 39 Pulling Heads for Sliplining**  
(These pulling heads are not suitable for HDD)

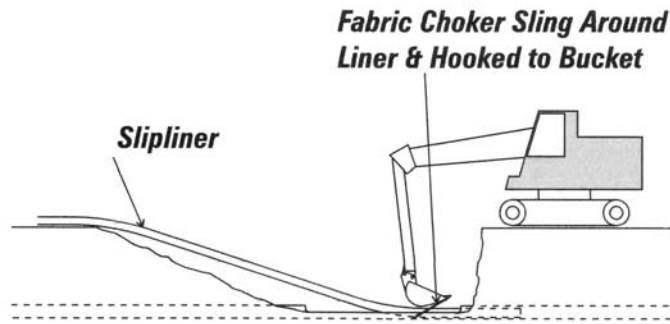
**Fabricated Steel Pulling Head**



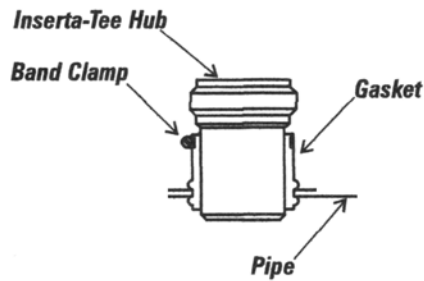
**PE Cap or Reducer Pulling Head**



**Figure 40 Backhoe Slipliner Push-In Technique**



**Figure 41 Inserta-Tee®**



Once the service connection is completed, the casing to liner annulus must be sealed to prevent backfill migration and the area must be backfilled. The annulus may be sealed using a mechanical seal, grout, concrete or cement-stabilized Class I or Class II soil. The point excavation initial backfill is commonly cement-stabilized Class I or Class II soils, compacted Class I or Class II soils, or concrete. Care should be taken to ensure the haunch areas are filled and compacted.

### ***Proprietary Trenchless Rehabilitation***

Proprietary trenchless rehabilitation techniques typically employ patented or licensed technologies and equipment to either replace a pipe (pipe bursting) or rehabilitate a host pipe (tight-fitting liners).

**DISCLAIMER: Because proprietary trenchless rehabilitation techniques can apply significant and unusual stresses during installation and because installation is beyond Performance Pipe's control, Performance Pipe assumes no responsibility for and expressly disclaims all liability relating to products installed using proprietary trenchless technologies.**

#### **PIPE BURSTING**

In pipe bursting, a bursting head is attached to a polyethylene pipe string. When pulled into the host pipe, the bursting head breaks the host pipe into pieces, enlarges the hole and installs the new pipe. Pipe bursting can provide increased capacity where the host pipe can be used as a guide path to install a larger pipe. Since the original host pipe is destroyed during installation, the new pipe must be structurally designed for the necessary static and dynamic loads. Pipe bursting is limited to host pipes that can be fractured and appropriate soil conditions.

#### **TIGHT-FITTING LINERS**

Tight-fitting liner techniques generally employ a means to temporarily reduce the diameter of the liner by mechanical technologies such as swaging, rolling-down, or deforming or other technologies. The reduced diameter liner is pulled into the host pipe, and then expanded to fit closely to inside diameter of the host pipe. The liner restores leak tightness, but the condition of the host pipe determines the structural integrity of the rehabilitated pipeline. Tight fitting liners maximize the flow potential through the rehabilitated line and minimize excavation, however, service connections may not be leak tight.

### **SURFACE INSTALLATIONS**

Surface installations of DriscoPlex™ OD controlled pipe normally require fully restrained joints such as heat fusion, flanges and fully restrained

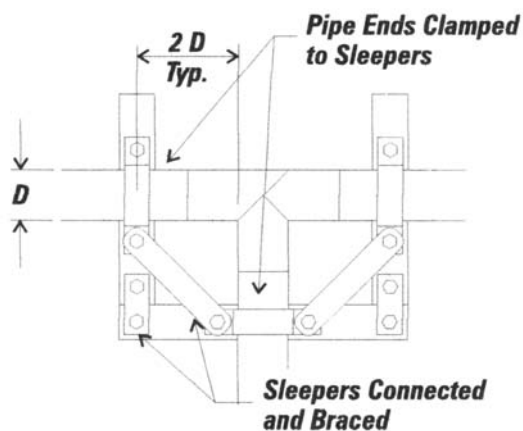
mechanical couplings. Primary installation considerations are to accommodate thermal expansion and contraction and to control bending stresses and strains at rigid structures. **Sunlight heating may require elevated temperature pressure ratings.**

Under the summer sun, black polyethylene pipe may reach temperatures up to 140° F and may be cooled to sub-zero temperatures in wintertime. In response to these temperature extremes, polyethylene pipe will expand and contract, both diametrically and longitudinally. For long piping runs, thermal length changes can be very significant. See the *Performance Pipe Engineering Manual* for design information.

Thermal length change may be accommodated with lateral deflection expansion loops that allow the pipe to snake side to side. **Expansion joints are not recommended.**

Surface pipelines should be placed on a smooth, uniform bed, wide enough to accommodate lateral deflection movement. The bed should be free of large rocks, clumps, clods and projecting stones or debris. Continuous support is preferred, however, small ditches, and open spaces may be crossed if they are less than the minimum support spacing distance for the pipe (Table 13). Greater spans require structural support.

**Rigid structures and connections must be protected against excessive bending stresses or failures may occur. Fabricated fittings 16" IPS and larger are rigid structures and must be protected against bending stresses. Rigid connections such as paired flanges, or flanged connections to rigid pipe, valves, or other rigid structures or devices must be protected against bending stresses at the connection. See Figures 34 and 42.**

**Figure 42 Surface Tee Bending Protection**

Valves and other such heavy devices must be structurally supported exclusive of the pipe and the connections must be protected against excessive bending stresses. The device should be mounted to foundation structure such as sleepers or a concrete slab, then provide bending protection such as that shown in Figures 34 and 42.

A pipe run along the surface will expand and contract with temperature changes, and will snake side to side. If it is necessary to confine pipe movement to a general right-of-way, the pipe should be laid between paired posts spaced about every 50 feet along the run. The distance from post to post across the pipe should be 2 pipe diameters or more. In some cases, a berm or embankment on one side of the line and posts on the other will serve the same purpose.

Occasionally, a surface pipe may be laid to run along the side of an embankment. To support the pipe, posts or support structures spaced at the recommended support spacing may be installed upslope above the pipe. The pipe is tethered to the posts with wire rope connected to clamps at least  $1/2$  pipe diameter wide around the pipe.

Tethering may also be used to support a pipe running vertically up an embankment. The top connection should be a structurally supported

flange with bending protection. At an appropriate supporting distance below the top flange, a flange pair should be installed for tether rope connections. At appropriate points to the side and above the tether connection flange, install posts or structures, and connect tether ropes from the posts to the tether flange. Tether ropes, flanges and support posts can be installed as required along the vertical run.

## ABOVE GRADE INSTALLATIONS

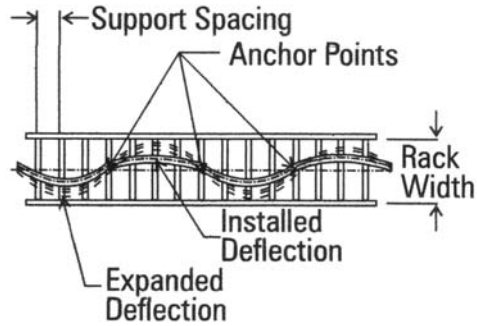
Like surface installations, above grade installations of DriscoPlex™ OD controlled pipe normally require fully restrained joints. Primary considerations are to accommodate thermal expansion and contraction and to control bending stresses at rigid structures. **Sunlight heating may require elevated temperature pipe pressure ratings.**

Above grade piping may be either supported in racks or hung from overhead supports. Racks must be wide enough to accommodate deflection from thermal expansion. If the rack is too narrow, the pipe may expand enough to fall off, or jump out, or damage adjacent piping or structures. Expansion joints generally provide unsatisfactory service with polyethylene pipe and are not recommended. Polyethylene pipe tends to deflect laterally rather than generate reactive thrust that would close the expansion joint. In pressure service, expansion joints simply expand out and cause further pipe deflection.

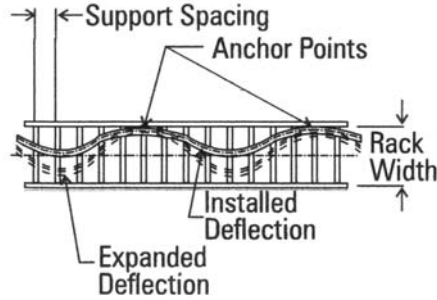
Rack beams supporting the pipe must be spaced at the recommended support spacing or less (Table 13). See the *Performance Pipe Engineering Manual* for information on rack design and thermal expansion and contraction.

Figures 43 and 44 illustrate example rack designs. Center anchored pipes deflect to either side of the centerline. Pipe anchors must pivot with pipe deflection. Side anchored pipes deflect to one side only and anchors can be fixed to one side.

**Figure 43 Pipe Rack, Center Anchored**



**Figure 44 Pipe Rack, Side Anchored**



When installing in racks, pipes are usually laid with an initial lateral deflection so additional deflection will continue to the same side. Some deflection should exist when the pipe has contracted and is at the lowest anticipated temperature.

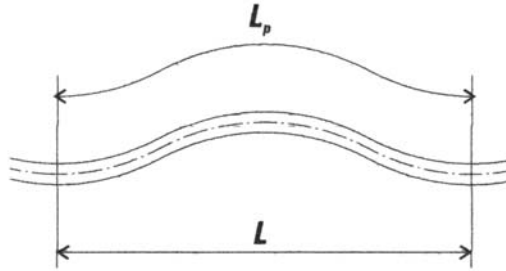
Additional pipe length should be provided so contraction at low temperature will not completely straighten out the pipe. Determine the length change,  $\Delta L$ , for the change from ambient temperature at the time of installation, to the minimum expected temperature, add approximately 10% as a safety factor; then add this length to the anchor point distance,  $L$ . The length of the expanded pipe may be determined from:

$$L_p = L + 1.1\Delta L$$

Where

$L_p$  = expanded pipe length, ft

**Figure 45 Deflected Pipe Installation**



## UNDERWATER INSTALLATION

Underwater lines must be ballast weighted to prevent floatation. See Submergence Weighting earlier in this handbook or ballast weight design in the *Performance Pipe Engineering Manual*. Ballast weights may be installed on shore or on barges over water. The line is then floated into location and sunk into position. Typical ballast weight design allows an air-filled pipeline to float with ballast weights attached if both ends of the pipeline are capped. Temporary floats such as barrels tethered to the line may be required to control sinking if the line is designed with heavy ballast weights.

On shore, ballast weight installation can be eased with a skid way to slide ballasted pipe into the waterway. Over water, barge mounted cranes may be used to lift and move ballast weights and pipe. Care must be taken not to kink the pipe.

Once ballasted, the pipeline is moved into position with marine craft or pulled into position with cables. Temporary anchoring may be used to maintain position during sinking. Water is introduced from the shore end, and air bled out slowly from the opposite end. Water must not be allowed to run the full length of the pipe. The shore end should be raised

slightly to create a u-bend of water that moves down the line as the line sinks. The floating air bleed end should be elevated above the water to prevent water entry. Bleeding air from the floating end controls the water entry rate. Sinking rate must be controlled so the pipe does not bend too tightly and kink.

If the pipeline is to be buried, all trench excavations must be performed before sinking. To aid in placement, underwater backfill should be coarse soil such as gravel or crushed rock. If additional erosion protection is necessary, riprap, such as large stones or broken pavement, may be placed over the initial backfill.

## INSPECTION AND TESTING

### *Damage Assessment*

Damage may occur during construction handling and installation. Significant damage may impair the future performance of the pipeline. Damaged pipe or fittings should be inspected and evaluated to determine if the damage impairs serviceability. The following guidelines may be used to assess damage significance.

For DriscoPlex™ pressure piping systems, damage or butt fusion misalignment in excess of 10% of the minimum wall thickness required for pipeline operating pressure may be significant. If the pipeline is to operate at the maximum permissible pressure for the material and DR, the damage allowance is 10% of the pipe minimum wall thickness. On the other hand, if the pipe is to operate at lower pressure, damage depth may be greater.

The shape of the damage should also be considered. For small damage areas where the depth is not excessive, sharp notches and cuts should be dressed smooth so the notch is blunted. Blunt scrapes or gouges should not require attention. Minor surface abrasion from sliding on the ground or insertion into a casing should not be of concern.

- **Pipe or fittings that have sustained service impairing damage should not be installed.** Post-installation damage may require that the damaged pipe or fitting be removed and replaced.
- **Scrapes or gouges cannot be repaired by filling-in with extrusion or hot air welding. The damaged section should be removed and**

**replaced.**

- **Improperly made fusion joints cannot be repaired.** Improper or misaligned butt fusions must be cut out and re-done from the beginning. Poorly joined socket or electrofusion fittings must be removed and replaced. Poorly joined saddle fittings must be removed by cutting out the main pipe section, or, if the main is undamaged, made unusable by cutting the branch outlet or chimney off the saddle fitting, and installing a new saddle fitting on a new section of main. Socket fusion fittings cannot be reused.
- **Broken or damaged fittings cannot be repaired.** They must be removed and replaced.
- **Kinked pipe must not be installed and cannot be repaired.** Kinked pipe must be removed and replaced.
- **Pipe damaged during an emergency squeeze-off cannot be repaired.** Squeeze-off damaged pipe must be removed and replaced.

### ***Leak Testing***

*If leak tests are required in the Contract Specifications, leak tests should be conducted in accordance with Performance Pipe Technical Note PP-802 recommended procedures.*

Leak tests should not be confused with pressure tests. Leak tests using a pressurized fluid media are intended to find leaks in a piping system.

Pressure tests are used with some piping materials to verify the pressure capacity of the pipeline. The pressure rating of polyethylene pipe, however, is based on long term sustained pressure tests, not short-term material properties. For polyethylene pipe, short-term pressure tests cannot verify long-term performance and are incapable of verifying the pressure capacity of the pipeline.

Liquids such as clean water are preferred as the test medium because less energy is released if the test section fails catastrophically. During a pressure test, energy (internal pressure) is applied to stress the test section. If the test medium is a compressible gas, then energy is used to compress the gas as well as apply stress to the pipeline. If a catastrophic failure occurs during a pneumatic test, both the pipeline stress energy and the gas compression energy are explosively released. With an incompressible liquid as the test medium, the energy release is

only the energy required to stress the pipeline.

***WARNING: Death or serious injury can result from failure at a joint or connection during leak tests with a liquid or gas under pressure. Keep all persons a safe distance away during testing. The test section is to be supervised at all times during the test.***

***Ensure that all piping is restrained against possible movement from catastrophic failure at a joint or connection. When pressurized, faulty joints or connections may separate suddenly causing violent and dangerous movement of piping or parts. Correctly made joints do not leak. Leakage at a joint or connection may immediately precede catastrophic failure. Never approach or attempt to repair or stop leaks while the test section is pressurized. Always depressurize the test section before making repairs.***

## OPERATIONAL GUIDELINES

### ***Disinfecting Water Mains***

Applicable procedures for disinfecting new and repaired potable water mains are presented in standards such as ANSI/AWWA C651, *Disinfecting Water Mains*. ANSI/AWWA C651 uses liquid chlorine, sodium hypochlorite, or calcium hypochlorite to chemically disinfect the main. Disinfecting solutions containing chlorine should not exceed 12% active chlorine, because greater concentration can chemically attack and degrade polyethylene.

### ***Cleaning***

Pipelines operating at low flow rates (around 2 ft/sec or less) may allow solids to settle in pipe invert. Polyethylene has a smooth, non-wetting surface that resists the adherence of sedimentation deposits. If the pipeline is occasionally subject to higher flow rates, much of the sedimentation will be flushed from the system during these peak flows. If cleaning is required, sedimentation deposits can usually be flushed from the system with high-pressure water.

Water-jet cleaning is available from commercial services. It usually employs high-pressure water sprays from a nozzle that is drawn through the pipe system with a cable.

Pressure piping systems may be cleaned with the water-jet process or may be pigged. Pigging involves forcing a resilient plastic plug (soft pig) through the pipeline. Usually, hydrostatic or pneumatic pressure is applied behind the pig to move it down the pipeline. Pigging should employ a pig launcher and a pig catcher.

A pig launcher is a wye or a removable spool. In the wye, the pig is fitted into the branch, then the branch behind the pig is pressurized to move the pig into the pipeline and downstream. In the removable pipe spool, the pig is loaded into the spool, the spool is installed into the pipeline, and then the pig is forced downstream.

A pig catcher is a basket or other device at the end of the line to receive the pig when it discharges from the pipeline. **A pig may discharge from the pipeline with considerable velocity and force. A pig catcher provides a means of safe pig discharge from the pipeline.**

Soft pigs must be used with polyethylene pipe. **Scraping finger type or bucket type pigs will severely damage the pipeline, and must not be used.** Commercial pigging services are available if line pigging is required.

**GENERAL INFORMATION****Table 32 Conversion Factors**

<i>To Convert</i>	<i>Into</i>	<i>Multiply By</i>
acres	hectares	0.4047
acres	square feet	43,560
acres	square miles	$1.562 \times 10^{-3}$
acres	square meters	4047
atmospheres	psi	14.7
atmospheres	cms of mercury	76.0
atmospheres	Pascal (Pa)	101,325
barrels	gallons	42
BTU's	horsepower-hrs	$3.931 \times 10^{-4}$
BTU's/hr	watt	0.2931
centares	square meters	1.0
centimeters	inches	0.3937
centimeters	feet	$3.281 \times 10^{-2}$
centimeters	millimeters	10.0
centimeters	meters	$1.0 \times 10^{-2}$
chains	inches	792.0
cubic feet of water	gallons	7.48052
cubic feet of water	pounds @ 39.2°F	62.4266
cubic feet of water	pounds @ 62°F	62.3554
cubic feet	cubic meters	0.02832
cubic feet/minute	gallons/minute	7.4805
cubic feet/second	gallons/minute	448.831
degrees F (less 32)	degrees C	0.5556
degrees C	degrees F	1.8 (plus 32)
degrees per second	revolutions per minute	0.1667
diameter (circle)	area (circle)	0.7854
diameter (circle)	circumference	3.14159

<i>To Convert</i>	<i>Into</i>	<i>Multiply By</i>
diameter (circle)	side of an equal square	0.88623
feet	centimeters	30.48
feet	inches	12
feet	meters	0.3048
feet	rods	0.06061
feet/minute	miles/hour	0.01136
feet/second	miles/hour	0.6818
gallons (US)	cubic feet	0.13368
gallons (US)	cubic meters	0.003785
gallons (US)	liters	3.785
gallons (US)	pounds	8.3453
gallons/minute	cubic feet/second	0.002228
gallons/minute	cubic feet/minute	0.13368
grams	milligrams	1000
grams	pounds	0.002205
hectare	acre	2.471
hectare	square feet	107,639
horsepower	BTU/minute	42.44
horsepower	foot pounds/minute	33,000
horsepower	watts	745.7
inches	centimeters	2.54
inches	feet	0.08333
inches of mercury at 32°F	atmospheres	0.3342
inches of mercury at 32°F	psi	0.49117
inches of mercury at 32°F	feet of water at 62°F	1.1343
inches of water at 62°F	atmospheres	$2.455 \times 10^{-3}$
inches of water at 62°F	psi	0.03609
joules	BTU's	$9.480 \times 10^{-4}$
kilometer	meter	1000
kilometer	feet	3281
kilometer	miles	0.6214

<i>To Convert</i>	<i>Into</i>	<i>Multiply By</i>
kilowatt hours	BTU	3413
knots	miles/hour	1.1516
liters	cubic centimeters	1000
liters	cubic inches	61.02
liters	gallons (US)	0.2642
meters	feet	3.281
meters	kilometers	0.001
meters	miles	$6.214 \times 10^{-4}$
miles	kilometers	1.853
miles	feet	5280
miles	rods	320
miles/hour	feet/minute	88.00
miles/hour	kilometer/hour	1.609
ounces (avoirdupois)	pounds	0.0625
ounces (fluid)	cubic inches	1.805
ounces (fluid)	liters	0.02957
pints (fluid)	cubic inches	28.87
pints (fluid)	gallons	0.125
pounds	grams	453.5924
pounds	ounces	16
psi	Pascal (Pa)	6,894.76
psi	Mega Pascal (Mpa)	0.006895
quarts (dry)	cubic inches	67.20
quarts (liquid)	cubic inches	57.75
quarts	gallons	0.25
quart	liters	0.9463
revolutions	degrees	360
revolutions/minute	degrees/second	6
rods	feet	16.5
rods	meters	5.029
side of a square	diameter of an inscribed	1.4142

<i>To Convert</i>	<i>Into</i>	<i>Multiply By</i>
	circle	
square feet	acres	2.296 X 10 <sup>-5</sup>
square feet	square meters	0.0929
square feet	square miles	3.587 X 10 <sup>-8</sup>
square miles	acres	640
tons (long)	pounds	2240
tons (long)	kilograms	1016
tons (short)	pounds	2000
tons (short)	kilogram	907.185
watts	BTU/minute	0.5692
watts	foot pounds/second	0.73766
watts	horsepower	0.001341

**Table 33 PSI Conversion Factors**

<i>Multiply</i>	<i>by</i>	<i>To Obtain</i>
lb/in <sup>2</sup>	2.307	ft H <sub>2</sub> O
lb/in <sup>2</sup>	2.036	in Hg
lb/in <sup>2</sup>	0.006895	MPa
lb/in <sup>2</sup>	0.06895	bar
lb/in <sup>2</sup>	0.7032	m H <sub>2</sub> O

**Table 34 Properties of Various Liquids**

<i>Liquid</i>	<i>Weight, lb/cu ft</i>	<i>Specific Gravity (water = 1)</i>
Acid, acetic	66	1.06
Acid, muriatic 40%	75	1.2
Acid, nitric 91%	94	1.56
Acid, sulphuric 87%	112	1.8
Alcohol, ethyl (100%)	49	0.79
Alcohol (methyl) (100%)	50	0.80
Chloroform	95	1.52
Ether	46	0.70
Gasoline	42	0.67

Kerosene	51	0.81
Lye, soda (66%)	106	1.70
Milk	63	1.01
Molasses	87	1.40
Oils, minerals, lubricants	57	0.91
Oils, vegetable	58	0.93
Shellac	75	1.20
Turpentine	54	0.87
Water, 39.2°F (max. density)	62.43	1.00
Water, ice	56	0.90
Water, sea	64	1.03

**Table 35 Properties of Various Gases**

<i>Gas</i>	<i>Symbol</i>	$C_p/C_v=k$	<i>Sp gr.</i> <i>Air=1.00</i>	<i>Weight</i> <i>Lb/ft<sup>3</sup></i>
Air		1.406	1.00	0.7658
Carbon dioxide	CO <sub>2</sub>	1.300	1.529	0.11637
Carbon monoxide	CO	1.403	0.9672	0.07407
Ethane	C <sub>2</sub> H <sub>6</sub>	1.220	1.049	0.07940
Ethylene	C <sub>2</sub> H <sub>4</sub>	1.220	0.9748	0.7410
Helium	He	1.660	0.1381	0.01058
Hydrogen	H <sub>2</sub>	1.410	.006952	0.00530
Methane	CH <sub>4</sub>	1.316	0.5544	0.04234
Natural gas (approx. avg.)		1.269	0.6655	0.05140
Nitrogen	N <sub>2</sub>	1.410	0.9672	0.07429
Oxygen	O <sub>2</sub>	1.398	1.105	0.08463
Propane	C <sub>3</sub> H <sub>8</sub>	1.150	1.562	

**Table 36 Properties of Various Metals**

<i>Various Metals</i>	<i>Weight (lb/cu ft)</i>	<i>Tensile Strength, psi</i>
Aluminum, 2s	169	13,000 - 24,000
Aluminum, bronze	481	100,000
Bronze	552.0	50,000 - 145,000
Copper, cast, rolled	556	32,000 - 60,000
Iron, gray cast	450	18,000 - 24,000
Iron, malleable	461	25,000
Lead	710	3,000
Nickel	556	120,000
Silver	656	42,000
Steel, carbon	490	70,000
Steel, 18% Cr, 8% Ni	495	85,000
Zinc	440	10,000

**Table 37 Formulas**

Area of a circle	$\pi r^2$	3.1416 x radius <sup>2</sup>
Circumference of a circle	$2 \pi r$	6.2832 x radius
Area of a triangle	$\frac{1}{2} b h$	0.5 x base x height
Area of a square	b h	base x height
Velocity, fps	$V=0.4085 Q / d^2$	Q = GPM; d = pipe ID, in.

**INDEX****A**

Allowable Tensile Load (ATL)	107-112
Anchor	38, 48-49, 98, 100, 102, 104-105, 119-121
Application	8, 10, 13-23, 25-29, 36, 42, 47, 49-50, 71, 76, 87, 90, 107, 110
ASTM	13, 16, 18, 21-22, 29, 40, 42, 47, 90, 97, 111-112
AWWA	16, 18, 24-25, 29, 72, 74, 124

**B**

Backfill	12, 50, 79, 90-92, 94-95, 97-98, 101, 105, 115, 122
Back-up ring	75-77
Bedding	91, 94-95, 97-98
Bending loads	12-13, 98-99, 110
- protection	118-119
- radius	41, 95-96, 107
Bolting	77
Bolt tightening	81
Bolt torque	81-82
Burial	10, 15-16, 90
Butterfly Valve	37, 82-83

**C**

Cautions	10-11, 14, 66, 68, 95-96
Chain	12, 62, 107, 126
Chain saw	67
Chemical Resistance	27
Clamps	11, 72, 85-86, 100, 118
Coils	15, 63, 107
Cold bending	96, 107
Cold weather	13, 64, 70
Compaction	95
Compressed air	16, 23

Performance Pipe Field Handbook

Compression coupling	65, 72, 85-86, 89
- energy	123
- molded	21
- set	81
- sleeve	72, 84-85
Contraction	38, 42, 106, 117, 119-120
Conversion Factors	126, 129
Cooling	70-71
<b>D</b>	
Damage	11-13, 15-16, 57, 61-66, 70, 89-90, 96-97, 108, 111, 119, 122-123, 125
Damage assessment	122
Data logger	70
Density	16, 21, 58, 130
Density, Standard Proctor	95, 101
Density, foam	57
Design factor, ATL	108
Design factor, environmental	22-23
Design factor, temperature	22-23
Design factor, tensile yield	108
Dimensions	52, 79
Dimension ratio (DR)	19, 22, 95, 105, 107-108
Dimension ratio, Standard (SDR)	22, 108
Disinfecting	124
<b>E</b>	
Equivalent lengths	37
Excavation	15, 90, 93, 106, 110, 112, 115-116, 122
Expansion	41-42, 106, 110, 117, 119
- coefficient	21, 38, 40
- joint	41, 117, 119
<b>F</b>	
Fabricated Fittings	24, 96, 117
Flange	65, 72-83, 87, 89, 95-96, 99, 100, 102-103, 116-117, 119
- adapter	75-78, 82, 103

Performance Pipe Field Handbook

- bolting	77-78, 80-83
- gasket	75, 77
- retightening flange bolts	81
- tightening flange bolts	80-83
Flow	13, 16, 22, 24-26, 28, 30-32, 34, 36, 47-48, 71-72, 90, 102, 116, 124
Foam	57
Frozen	13, 92, 101
Fusion	8, 11, 66, 69-70, 74, 89, 102, 123
- bead	69
- butt	11, 68-70, 72, 74, 103, 106, 122-123
- electro-	65, 71, 89, 112, 123
- equipment	14, 70,
- heat	8, 11, 65, 67-68, 116
- joining procedure	68, 70-71, 74
- saddle	68, 70, 72, 87, 112
- socket	68, 71-72, 123
<b>G</b>	
Gas flow	13, 28, 36
Gasket	65-66, 73-78, 80-81, 85, 87, 89
Gland	73-74
<b>H</b>	
Handling	10-12, 14, 60-66, 74, 87, 90, 95, 122
Hangers	42
Hazen-Williams	28-30
Heat tracing tape	41
Hydrocarbon, liquid	11, 23
Hydrostatic Design Basis (HDB)	21-22
Hydrostatic loads	49, 111
Hydrostatic pressure	125
<b>I</b>	
Impact	13, 39, 64-65
Index pattern	80-81, 83
Insert fitting	72, 85

Performance Pipe Field Handbook

Insert stiffener	84-85, 89
Insertion renewal	69, 111
<b>K</b>	
Kink(ing)	41, 107, 121-123
<b>L</b>	
Lifting	12, 61-62, 95
Locating	15
<b>M</b>	
Manhole	47-48, 112
Melt index	21
Misalignment	73, 122
MJ Adapter	65, 72-74, 102-103
Modulus	24, 39-40, 44
Molded fitting	23
Molded plaque	21, 40
<b>P</b>	
Parallel pipe clearance	93
Permeation, liquid hydrocarbon	11
Physical Property	19, 21
Pipe Support	42
Poisson effect	101-103, 105-106
Poisson ratio	102, 105-106
Precautions	11, 14-15, 66, 95-96
Pressure Rating	18-19, 22-26, 75, 117, 119, 123
Pressure testing	105
Properties of various gases	130
Properties of various liquids	129
Properties of various metals	131
Pullout	72, 101-106
<b>R</b>	
Rehabilitation	32, 113, 116
Repair	11-12, 14, 66, 71-72, 89-90, 122-124
Retightening flange bolts	81
<b>S</b>	

Performance Pipe Field Handbook

Sidewall	70, 93
Slings	12, 61-62
Soil Type	97
Squeeze-Off	14, 123
Stacking	63-64
Static Electricity	13-14
Steam	15
Storage	10, 20, 61-65, 101
Stub-end	78, 82
Stub-out	48
Sunlight	20, 22, 117, 119
Support Spacing	44-46, 57, 117-119
Surge	24-27, 105-106
<b>T</b>	
Tamping	97
Tapping tee	87-88
Tapping sleeve	88-89
Temperature, brittleness	21
Temperature, service	15, 22-23, 44, 87
Temperature, subfreezing	13
Tensile break [strength]	108
Tensile strength	21, 71, 77, 131
Tensile yield [strength]	108-110
Testing	10, 12, 40, 122
- chemical	28
- fusion	70
- leak	12, 105-106, 123-124
- pressure	105
Thermal Expansion	21, 36, 40-42, 106, 110, 117, 119
Thrust Block	68, 98, 102, 105
Tightening, flange bolts	80-83
- MJ adapter gland bolts	73-74
- sequence [pattern]	73, 80
- torque	74, 80-83

Performance Pipe Field Handbook

Trench box	93-94
Trench width	92-93, 107
Trenching	15, 9293, 107
Trenchless	137
<b>U</b>	
Ultraviolet	20
Uncoil	13, 64
Unrestrained	38, 50, 101-105
<b>V</b>	
Vacuum	28, 88
Valve	24, 28, 37, 79, 82-83, 88, 99, 103, 117-118
Velocity	24-27, 31-32, 125, 131
<b>W</b>	
Welding	11, 68
Welding, extrusion	11, 71-72
Welding, hot air	11, 72
Wire rope	12, 62, 118
<b>Y</b>	
Yield	84, 108-110