

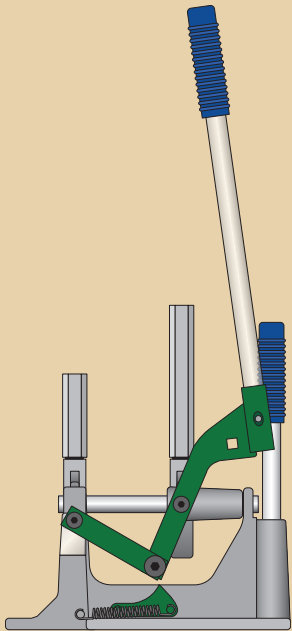

In-Ditch Fusion



Butt Fusion



No. 216



McElroy No.2LC Machines butt fuse $\frac{1}{2}$ " CTS – 2" IPS (16 mm – 60 mm) pipe. The No.2LC (Locking Cam) incorporates McElroy's patented Centerline Guidance System, and is designed to butt fuse tees, ells, and other fittings with consistent high quality results. The machine's semi-automatic locking cam system maintains force during the cooling cycle.

The machine is primarily made of surface hardened aluminum for light weight and durability. The jaws and inserts have multiple serrations for maximum grip on the pipe.

- Lightweight and durable
- Semi-Automatic locking cam
- Economic alternative
- Features new compact heater

No.2LC Fusion Machines

Package includes: fusion machine, facer, Multi-Mc heater, butt fusion heater adapter set, insulated heater/facer stand, screw/driver kit, and operator's manual.

FEATURING

The New Compact Heater Handle

Upgrade kits are available.

Description	Part No.
100-120V, 50/60Hz, 1Ph	A217201
200-240V, 50/60Hz, 1Ph	A217202

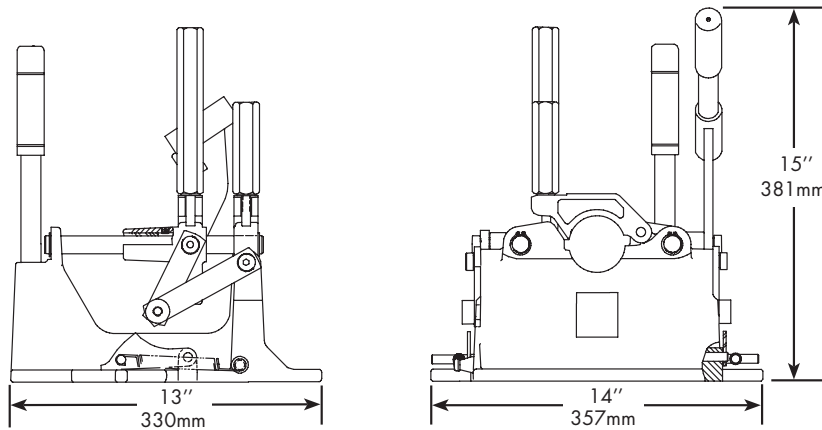

weight 23lbs (10.4kg) **input power** 800 Watts

Multi-Mc™ Heater Kits

Heaters have a microprocessor control and dial thermometer to monitor temperature. Includes butt adapter plates.

Description	Part No.	
100-120V, 50/60Hz, 1Ph	A215505	
200-240V, 50/60Hz, 1Ph	A215506	

Spare Butt Plate Kit

Heater adapters have an anti-stick coating and are required for butt fusion.

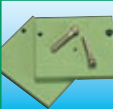
Description	Part No.	
Kit = 2 Adapter Plates	A215701	

Includes attaching screws.

Insert & Adapter Box

Storage box for organizing your inserts and adapters for safe keeping.

Description	Part No.	
Storage Box	A200901	

No.2LC Storage Box

Storage box for No. 2LC Fusion Machine, inserts and adapters.

Description	Part No.	
No.2LC Storage Box	MJQ00193	

Heat Shield

For fusing two materials with different melt rates. Shields the faster melt rate materials from overmelting.

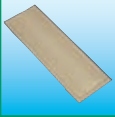
Description	Part No.	
Heat Shield	203004	

Screw/Driver Kit

Spare Driver Kit with insert screws and wire brush for cleaning serrated jaws and inserts.

Description	Part No.	
Driver Kit	A214201	

Spare Facer Blades

Description	Part No.	
Blade Set = 4 Blades	205702	

Pyrometer Kit

Pyrometer kit for accurately checking surface temperatures of heater.

Description	Part No.	
Digital Meter	A218803	

No.2LC Accessories:



Spare Facer & Stand



Heater sold separately

Description	Part No.
Spare Facer	216101
Spare Stand with Heater Bag	218301

Butt Fusion Inserts

Description	Part No.
½" IPS	207521
¾" IPS	207512
1" IPS	207513
1¼" IPS	207514
1½" IPS	207515
½" CTS	207516
¾" CTS	207517
1" CTS	207518
1¼" CTS	207519
1½" CTS	207533
20mm	207523
25mm	207525
32mm	207527
40mm	207529
50mm	207531



Inserts are surface hardened for longer life and are serrated for maximum grip on the pipe. Inserts are made for one size pipe only and are required for pipe sizes less than 2" IPS or 60mm. **Set = 4 inserts.**

Note: Other sizes of inserts are available upon request. Contact your McElroy representative about inserts to fit your needs.

For JIS sizes see pg. 40-1