

No. 824



MegaMc® No.824 Machines will butt fuse pipe sizes from 8" IPS – 24" OD (225mm – 630mm). The machine allows for butt fusion of most fittings without special holders or removal of outer jaw. Mitered inserts are available for fabricating ells. McElroy's unique semi-automatic control system requires only one operator. Hydraulic power assists all fusion functions including the complete operation of the jaws, pipe lifts, heater, and facer. It also incorporates McElroy's patented Centerline Guidance System and is DataLogger® compatible.

MegaMc® No.824

- Hydraulic Clamping
- Hydraulic Pivoting Heater and Facer
- Centerline Guidance System
- DataLogger® Compatible
- Four Jaw Construction



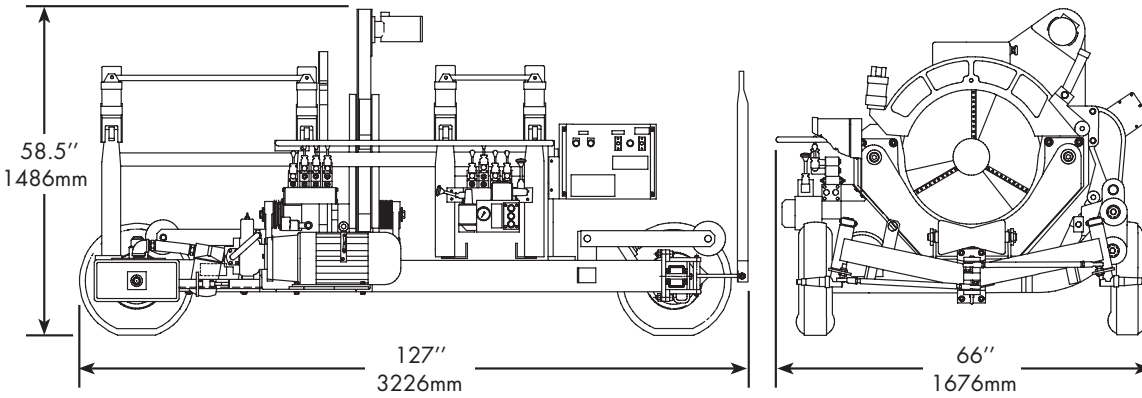

weight 3800lbs (1724kg) **input power** 20 KVA

No.824 Fusion Machines

Package includes: fusion machine, facer, heater, butt fusion heater adapter set, insulated heater stand, 24" OD butt fusion inserts, lifting assembly, and operator's manual.

220-240V, 50/60Hz, 3 Ph	Part No.
High Force Cylinders	A2400701
Medium Force Cylinders	A2400702
Low Force Cylinders	A2400706

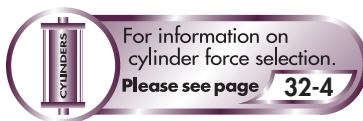

MegaMc No.824 Accessories:

Pipe Support Stand

Height is adjustable to properly support, position and align pipe to be fused.

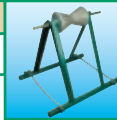
Description	Part No.	
Support Stand	2429101	

Spare Butt Plate Kit

Heater adapters have an anti-stick coating and are required for butt fusion.

Description	Part No.	
Kit = 2 Adapter Plates	A2428506	

Includes attaching screws.

Spare Facer Blades

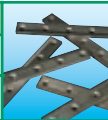
Description	Part No.	
Set = 6 Blades 9" lg.	3615710	
Set = 6 Blades 11" lg.	3615712	

Pyrometer Kit

Pyrometer kit for accurately checking surface temperatures of heater.

Description	Part No.	
Digital Meter	A218803	

Stub End Holder

Holds stub end for butt fusion.

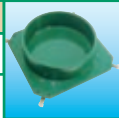
Description	Part No.	
Holder	2419501	



DataLogger Compatible
 A handheld computer used to document the profile of each fusion joint. See page 28-1.

Butt Fusion Inserts

Inserts are made for one size pipe only and are required for pipe sizes less than 630mm. Not all inserts fit directly in the jaws. Some inserts nest inside other inserts, called master inserts.

Set = 8 Inserts

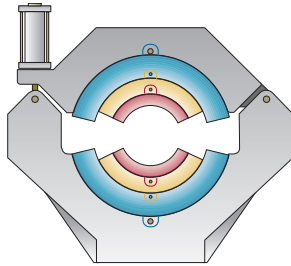

Cast Fabricated

VERSUS

Cast Inserts

Cast inserts are made from a high strength aluminum alloy, for light weight and easy handling, and have been surfaced hardened for longer life. All inserts are serrated for maximum grip on the pipe.

Fabricated Inserts

Fabricated inserts are constructed out of precision laser cut steel and rolled components to ensure proper alignment in the jaws. They are normally lighter in weight than cast inserts.

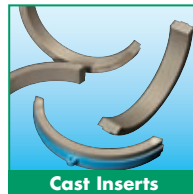

NOTE: Other sizes of inserts are available upon request. Contact your McElroy representative about inserts to fit your needs.

All inserts below fit in No.824 jaws

Inserts	Pipe OD	Cast Set #	Fab. Set #
24" JAW	24.80 (630mm)	N/R	N/R
24" OD	24.00 (610mm)	Inc w/pkg	2402301
22" OD	22.00 (560mm)	2411919	N/A
20" DIPS	21.60 (549mm)	2411922	N/A
20" OD	20.00 (508mm)	2412010	N/A
500 mm	19.69 (500mm)	2412011	N/A
18" DIPS	19.50 (495mm)	2412023	N/A
18" Master	18.00 (457mm)	2411708	N/A

All inserts below require 18" Master insert

Inserts	Pipe OD	Cast Set #	Fab. Set #
450 mm	17.72 (450mm)	N/A	2418201
16" DIPS	17.40 (442mm)	2412117	2418301
16" OD	16.00 (406mm)	2412110	N/A
400 mm	15.75 (400mm)	2412111	N/A
14" DIPS	15.30 (389mm)	2412215	N/A
14" OD	14.00 (355mm)	2412206	N/A
340 mm	13.39 (340mm)	2411811	N/A
12" DIPS	13.20 (335mm)	2411826	N/A
12" Master	12.75 (324mm)	2411810	N/A

All inserts below require 12 & 18" Master inserts

Inserts	Pipe OD	Set No.
315 mm	12.40 (315mm)	1211202
10" DIPS	11.10 (282mm)	1207221
280 mm	11.02 (280mm)	1207205
10" IPS	10.75 (273mm)	1207204
250 mm	9.84 (250mm)	1213503
8" DIPS	9.05 (230mm)	1207107
225 mm	8.86 (225mm)	1207010
8" IPS	8.63 (219mm)	1207104

MegaMc No.824 Accessories:

Mitered Inserts



Used to fabricate segmented ells. Inserts are made for one size pipe only. Some inserts nest inside other inserts, called master inserts.

Set = 4 Inserts + 1 Template

NOTE: Other sizes and angles of mitered inserts are available upon request. Contact your McElroy representative about inserts to fit your needs.

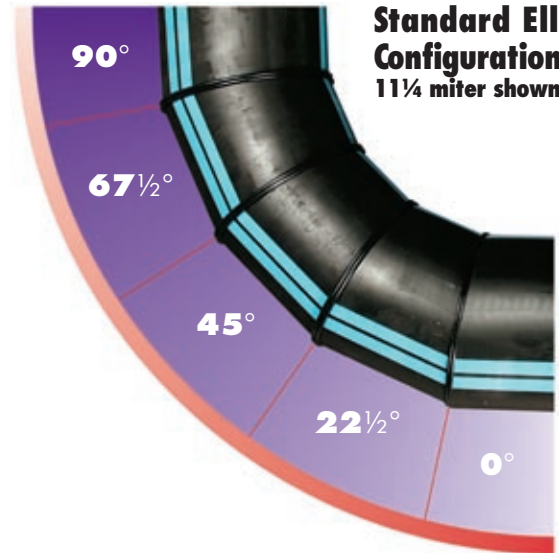
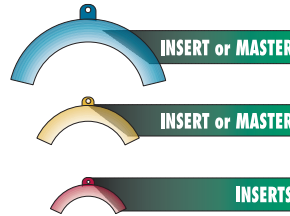
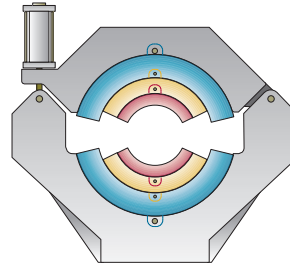

Standard Ell Configuration
1 1/4 miter shown

All inserts below fit in No.824 jaws

Inserts	Pipe OD	Set No.
20" DIPS x 1 1/4	21.60 (549mm)	2421257
20" OD x 1 1/4	20.00 (508mm)	2421217
18" DIPS x 1 1/4	19.50 (495mm)	2421251
18" OD x 1 1/4	18.00 (457mm)	2421215
16" DIPS x 1 1/4	17.40 (442mm)	2421245
18" Master	18.00 (457mm)	2411708

All inserts below require 18" Master insert

Inserts	Pipe OD	Set No.
16" OD x 1 1/4	16.00 (406mm)	2420619
14" DIPS x 1 1/4	15.30 (389mm)	24206122
14" OD x 1 1/4	14.00 (355mm)	2420617
12" DIPS x 1 1/4	13.20 (335mm)	24206110
12" IPS x 1 1/4	12.75 (324mm)	2420615
10" DIPS x 1 1/4	11.10 (282mm)	24206116
12" Master	12.75 (324mm)	2411810

All inserts below require 12" & 18" Master inserts

Inserts	Pipe OD	Set No.
10" IPS x 1 1/4	10.75 (273mm)	1214232
8" DIPS x 1 1/4	9.05 (230mm)	1214269
8" IPS x 1 1/4	8.63 (219mm)	1214230